

**LCR Meter
SM6019**

User Manual

scientific

Copyright © Scientific All rights reserved.

This instrument contains proprietary information, no part of this manual may be photocopied , reproduced or translated without any prior written consent.

Information in this manual supercede all corresponding previous released material.

Scientific continues to improve products and reserves rights to amend part or all of the specifications , procedures, equipment at any time without notice.

Rev 1.01 / 0111



Scientific Mes-Technik Pvt. Ltd.,

B-14 Industrial Estate, Pologround,
INDORE 452015(INDIA)
Tel : 0731-2422330/31/32/33
Fax : 0731-2422334,561641
Email : info@scientificindia.com

LCR Meter SM6019

Table of Contents

1. Introduction	4
2. Technical Specifications	5
3. Terms & Symbols	7
4. Front Panel Controls	10
5. Operating Instructions	13
General Information	13
Safety	13
Operating Conditions	13
First Time Operation	14
Understanding & Measuring Passive Components	14
Understanding Displayed Parameter	16
Measurement of Transformer Parameters	17
Component Sorting & Binning Function	19
Equivalent Circuits	19
Display Types	20
Menu	20
Zero Compensation	22
Frequency of Test	23
Impedance Range	24
Precision & Accuracy	25
Basic Accuracy Graph	27
6. Maintenance	29
7. Despatch Procedure for Service	29
8. Warranty	30
9. List of Service Centers	31

LCR Meter SM6019

- **Comprehensive range of functions, L+Q, C+D, R+Q, $|Z|+\theta$, R+X, G+B, L+AL etc.**
- **Measurement accuracy 0.2 %**
- **Test frequencies standard 100 Hz to 25 kHz in 11 steps, and an additional User defined, from 500 possible frequencies between 100 Hz and 25 kHz**
- **Simultaneously two measured parameters displayed**
- **Absolute value, Δ value, % value**
- **Bin function for component sorting**
- **Compact and Low Cost**

The LCR Meter **SM6019** is LCR measuring bridge, an impedance measuring instrument allowing automatic measurement of resistance, capacitance, inductance, measurement of some parameters of Transformer, $1\text{m}\Omega$ to $100\text{M}\Omega$. The bridge has basic accuracy of 0.2% and has 11 standard Frequencies and one definable / selectable by the user. The instrument has a powerful microcontroller with logic circuits, allowing to control the display, keyboard and component measurement.

An internal bias voltage of 2 Volts can be selected for use when testing electrolytic capacitors. This instrument is equipped with self test and self calibration menu, for calibrating the instrument at regular interval without opening the case.

Technical Specifications

Measurement Modes	:	Auto / Manual L+Q, C+D, R+Q, Z + θ , R+X, G+B, N+ θ , N ⁻¹ + θ , Vs+Vp, M, L+AL
Equivalent Circuit	:	series or parallel
Parameters displayed	:	Value, Δ value, Δ % value
Measurement Ranges	:	Auto or Manual
L + Q	:	L : 0.01 μ H to 9999 H Q : 0.0001 to 100
C + D	:	C : 0.001 pF to 99999 μ F D : 0.0001 to 10
R + Q	:	R : 1 m Ω to 99.9 M Ω Q : 0.001 to 100
Z + θ	:	Z : 1 m Ω to 99.9 M Ω θ : -180.00 $^\circ$ to +180.00 $^\circ$
R + X	:	R : 1 m Ω to 99.9 M Ω X : 1 m Ω to 99.9 M Ω
G + B	:	G : 0.01 μ S to 1000 S B : 0.01 μ S to 1000 S
N + θ	:	N : 1 to 9999 θ : -180.00 $^\circ$ to +180.00 $^\circ$
N ⁻¹ + θ	:	N ⁻¹ : 0.0001 to 1 θ : -180.00 $^\circ$ to +180.00 $^\circ$
Vp + Vs	:	Vs : 230 V/N or 115 V/N, 0.01 V resolution Vp : 115 V or 230 V
M	:	M : 0.01 μ H to 99.99 H
L + AL	:	L : 0.01 μ H to 9999 H AL : L/N ² (N definable by the user 1 to 999)
Test conditions		
Test frequencies	:	100 Hz, 120 Hz, 250 Hz, 500 Hz, 1kHz, 2.5 kHz, 5 kHz, 7.8 kHz, 12.5 kHz, 15.6 k Hz, 25 kHz
Test voltage	:	0.5 Vrms \pm 10% (HI) and 0.05 Vrms \pm 10% (LO)
Measurement Speed	:	2 measurement per second (without averaging)

Measurement Accuracy

Basic Accuracy	:	$\pm 0.2\%$ ($15\ \Omega < Z < 300\text{k}\ \Omega$ and $f < 1\ \text{kHz}$) Accuracy varies with range and frequency selected, (valid at $23^\circ\text{C} + 5^\circ\text{C}$ after a 30 min. Warm up period) Please refer Basic Accuracy Graph below.
Connection	:	4-wire Kelvin on BNC guarded connector for probes and fixtures connections.
Protection	:	Protected up to 1 Joule of energy, max 100 VDC (For charged Capacitors)
Zero Compensation	:	Auto calibration on each frequency , Open or Closed . Limits Compensation Closed : $R < 8\ \Omega$, $ Z < 8\ \Omega$ Open : $ Z > 1\ \text{M}\ \Omega$
Averaging	:	Selectable 2 to 8 measurements
Sorting function	:	Tolerance selectable Auto, ± 0.1 , 0.2, 0.5, 1, 2, 5, 10 or 20%
Bin function	:	5 binning B1, B2, B3, B4 & B5 at 0.1, 0.5, 1, 2, 5 %, tolerances
DC Bias	:	Internal 2V

General Information

Measurement results displayed on back lit LCD display. Zero calibration provided in Menu for compensating with probe connected.

Calibration Interval	:	One year (recommended)
Supply	:	230 V $\pm 10\%$, 50 Hz AC Wattage : 10 VA approx.
Operating Conditions	:	0 - 50 °C, RH < 80 %
Dimensions	:	W 205 , H 95, D 292 mm
Weight	:	2.1 kg (approx)

Accessories :

Standard	:	BNC to Kelvin Probe, BNC to Crocodile Clip (4 mm), User Manual, Spare fuse
Optional	:	Precision Kelvin Probe, SMD Probe

(Subject to change)

Terms & Symbols

Parameter	Measurement	Symbol of Unit
Z	Complex impedance	Ω ohm
Y	Admittance, $1/Z$	Siemens, S
Z	Module impedance Z,	ohm, Ω
Rs or ESR	Resistance Series, Real part of the Impedance	ohm Ω
X	Reactance Imaginary part of the Impedance	ohm Ω
G	Conductance, Real Part of admittance (Y)	Siemens, S
B	Susceptance, Imaginary Part of admittance	Siemens, S Siemens, S
Cs	Capacity Series	Farad, F
Cp	Parallel capacity	Farad, F
Ls	Series Inductance	Henry, H
Lp	Parallel inductance	Henry, H
Rp	Parallel resistance	Ω ohm
Q	quality Factor	Without unit
D	dissipation factor	Without Unit
θ	Phase angle	Degree
M	Mutual inductance	Henry H
N	Turns Ratio	Without Unit
Vp	Primary voltage (Transformer)	Volts AC, V
Vs	Secondary voltage (Transformer)	Volts AC, V

Unit of Measure

Multiplier	Scientific	Engineer	Symbol
1000000	10^6	Mega	M
1000	10^3	kilo	k
0.001	10^{-3}	milli	m
0.000001	10^{-6}	Micro	μ
0.000000001	10^{-9}	nano	n
0.000000000001	10^{-12}	pico	p

Glossary

Coil : A coil is made of a multiple turns of wire on conductor / Core. It has the property to oppose / resist changes in current. It is characterized by its Inductance.

Capacity : Characteristics of a Capacitor. The unit is the Farad (F).

Capacitor : Passive element consists of two conductors / plates separated by a dielectric. The capacitor has the property of passing the AC while blocking the DC. See also chapter capacity and reactance.

Test frequency : The frequency with which the measurement of parameters of component is done. The value of a parameter sometime depend on frequency.

Range : Range of resistance that the instrument uses to perform measuring function.

Impedance : Complex parameter defining a passive component. It include a real part (resistance) in series with some imaginary part (reactance). Standard or pure resistance has no reactance, while perfect coils and capacitors have resistance.

Inductance : Property of a coil to oppose any change in current . The inductance of a coil is in Henry (H).

Parameter : Electric property measured, The main or primary parameter is the property of most commonly sought component (capacity, inductance, Resistance). The second parameter of lesser importance characterized losses in the component (quality factor, dissipation, phase angle).

Accuracy : The difference between the measured value and the true value of component. The accuracy is expressed as a percentage for the principal parameter. The accuracy depends on the value of the impedance and the frequency. Typically the accuracy is a secondary parameter and is great importance.

Accuracy Background : The accuracy of LCR bridge depends on a number of parameters such as the frequency and impedance. The accuracy of the standard programmed database is checked with precision instrument in optimum conditions, i.e. at frequency of 1 kHz and for 100 Ω and 10 k Ω .

Source Resistance : Resistance in series with the testing signal generator. This resistance relates to the range of impedance.

Resolution : The smallest value that can be shown on the display of the instrument. Do not confuse this with the accuracy.

Test Voltage : This is the rms value of the alternating voltage that generates a current in the test component. Because of resistance and impedance of component under test, test voltage is always less than specified value.

Front Panel Controls

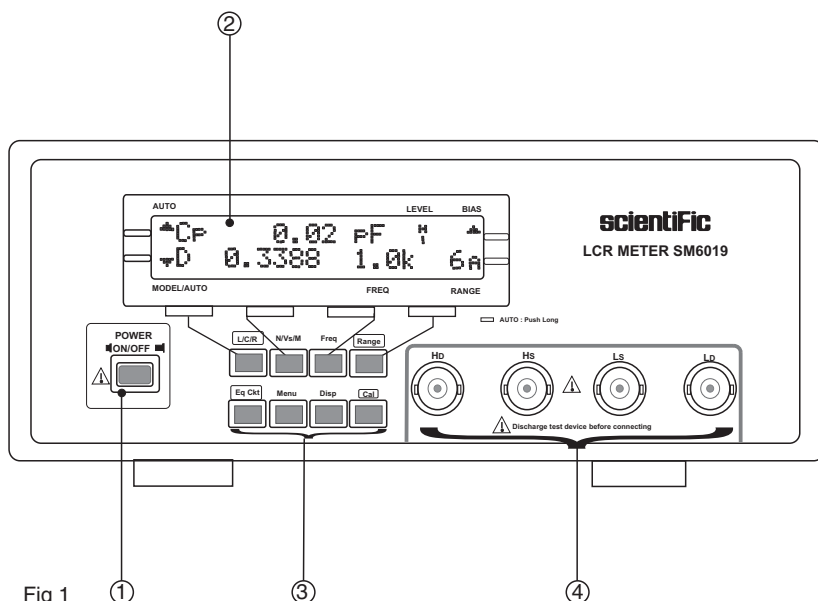

Fig 1

- ① **Power** : When push button pressed , switches power ON to the instrument.
- ② **Display** : LCD displays the measured value & parameters selected, the status of the instrument and different messages. In measuring mode the normal primary value (L, C, R, | Z |) is displayed on the first line while the associated secondary parameter (Q, D, X, θ) is displayed in the second line. The position of the decimal point is adjusted according to the function automatically. The symbol Δ front of the main parameter indicates that measurement is a relative measure or an absolute deviation compared to a nominal value. The presence of an arrow to the left of the first line indicates that the instrument is in automatic mode. The presence of a single arrow to the left of the second line indicates the instrument is placed in automatic equivalent circuit / model mode. The range of impedance is shown right from the second line. A letter 'A' form line number indicates that the instrument is in the auto range. In manual mode or maintaining same range mode an "H" becomes flashing. The frequency of testing is underway displayed on the right side of the second line. The word "USER" is displayed instead of digit if user programmed frequency of test is selected. Test signal level is shown by HI and Lo on first line on right side. Bias can be selected for biasing components and shown by arrow on right side of display by arrow when signal is biased.

③ **Keyboard** : The keyboard is used to select the functions of the instrument and configure different Parameters. Some keys have dual Functions, as simple push and long push. The Secondary function is noted different color on the panel .

L/C/R : This button selects the parameter, measuring parameters apart from transformers. By pressing successively this push button manually, you can change the function of the instrument to any one , from ; [L+Q] or [L+AL], [C+D], [R+Q], [|Z|+ θ], [R+X], [G+B]. When the push button is pressed for more than two seconds the instrument configuration is set to automatic parameter mode. In this mode the instrument function selects the most appropriate mode in view of the value of phase angle module and impedance. This mode is indicated by the presence of an arrow at the top left of the display. The various functions are described below. The Mode (L + AL) replaces the mode (L + Q) when the instrument is configured to AL mode (see MENU)

N / Vs / M : When push button pressed , selects the measurement parameters for transformers. Press this button to select the desired function

([N + θ] [N⁻¹ + θ] [Vs + Vp], [M]

[N + θ] : Report of the number of turns and phase shift primary /secondary

[N⁻¹ + θ] : Report of inverse the number of turns and phase shift primary /secondary.

[Vs+Vp] : Secondary voltage and primary voltage

[M] : Mutual inductance

Freq. : Push button when pressed , selects one of the 11 test frequencies available :

100 Hz, 120 Hz, 250 Hz, 500 Hz, 1 kHz, 2.5kHz, 5 kHz, 7.8 kHz, 12.5 kHz, 15.6 kHz, 25 kHz and User Freq. The frequency is indicated on the second line of the display . The user frequency is defined in one of the options in the menu.

Range : Push button when pressed , selects the appropriate range of impedance for the component under test. If the instrument is in automatic mode (the letter “A” is visible), pressing this button long, is used to freeze or hold the range of measure and instrument goes in manual mode. An “H” appears flashing before range. Extended press of buttons enters into auto mode. This function is used to measure large quantities of same value of component.

EQ Ckt : Push button selects between serial or parallel equivalent circuits used in calculation of the parameters. Push button for 2 second to return to auto mode. In this case, the instrument determines the generally more appropriate model.

Menu : Push button allows access to a number of settings and functions. The function is displayed on the bottom line of the LCD readout. To select the desired menu function, the first row of switches “LCR”, “N/Vs/M”, “Freq” & “Range” works as F1, F2, F3 & F4 respectively. The detailed explanation is included in for operation of Menu mode on page 19.

Disp : Push button selects how the value of a components will be displayed. Successive press of this button results in the different types of display of the measured value, the difference in value in relation to the current value and the percentage difference of the current value.

Cal : Push button provides access to open / closed calibration functions, also known as zero calibration or compensation of test leads. A menu appears on the second line of the screen displaying **Open Short Exit**. These options allow setting short circuit or open circuit of test for the test frequency. A brief press on cal button performs the same operation, but for all frequencies. In this case the screen displays **OPEN SHORT Exit**. (In capital letters).

- ④ **BNC connectors** (4 nos.) : Connect the appropriate test lead provided with the instrument, for the component measurements. Use supplied connectors for better measurements.

Operating Instructions

General Information

The logical front panel layout of **SM6019** ensures rapid familiarization with the various functions. However, even experienced operators should not neglect to carefully read the following instructions, to avoid any operational errors and to be fully acquainted with the instrument when later in use.

After unpacking the instrument, check for any mechanical damage or loose parts inside. Should there be any transportation damage, inform the supplier immediately and do not put the instrument into operation.

Safety

The case chassis and all measuring parts are connected to the protective earth contact. Without an isolating transformer, the instrument's power cable must be plugged into an approved three contact electrical outlet.

WARNING!

ANY INTERRUPTION OF THE PROTECTIVE CONDUCTOR INSIDE OR OUTSIDE THE INSTRUMENT OR DISCONNECTION OF THE PROTECTIVE EARTH TERMINAL IS LIKELY TO MAKE THE INSTRUMENT DANGEROUS. INTENTIONAL INTERRUPTION IS PROHIBITED.

When removing or replacing the metal case, the instrument must be completely disconnected from the mains supply. If any measurement or calibration procedures are unavoidable on the opened-up instrument, these must only be carried out by qualified personnel acquainted with the danger involved.

Replacement of mains fuse, in case of fuse blown, remove the mains cord connected to the instrument from mains outlet and from the instrument, on the rear of the instrument. With the help of small screw driver, pull the fuse holder cover, located on mains socket. A spare fuse is placed in the compartment, remove the fuse blown, and replace it with the spare fuse. The mains fuse rating is 150 mA, slo blo, 5 x 20 mm size. Use correct rating and size for replacement.

Operating Conditions

The ambient temperature range during operation should be between +0° to +45°C and should not exceed -40°C or +70°C during transport or storage. Prior to calibration a preheat run of approx. 30 minutes is required.

First Time Operation

Switching **ON** : Plug the mains cable into the mains socket at the rear of the instrument. Now plug the other end into a suitable mains outlet. To switch ON, press power ON switch . On application of power, the LCD displays range and functions etc . The LCR Meter is designed to set itself automatically to inductance measurement, parallel equivalent circuit, 1 KHz frequency, as it is switched on or sets to last set up stored in the instrument , depending on the selection. The internal circuitry normally takes a few seconds to stabilize after the instrument is switched ON.

Understanding and Measuring Passive Components

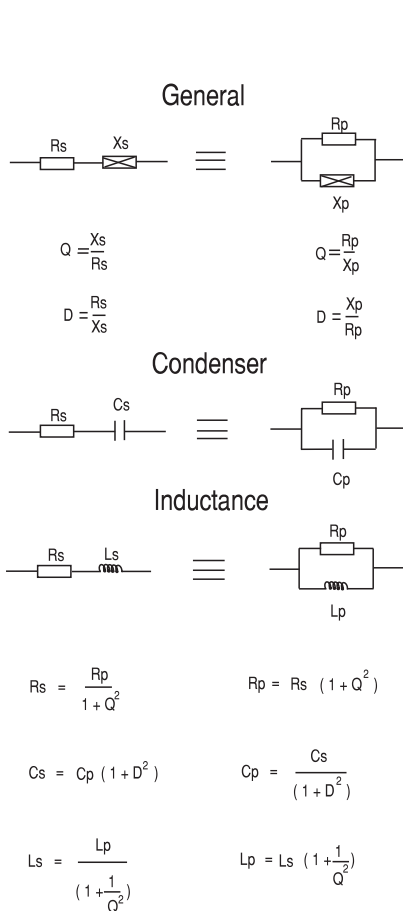

Fig 2

A passive component non-ideal (resistance, capacitor, and inductance) can be represented by its part (resistance) in part serial or parallel with a reactive part (capacitor or inductor).

The impedance is a function of frequency. The Eq ckt / model selectable is series and parallel (are mathematically equivalent) and can be switched normally from one to another by equations. Particular Eq ckt is more appropriate than other decided by conditions of measurement data, i.e. the resistance serial or parallel decided by physical construction. This also mean that serial or parallel resistance represents an actual size. Some of the components are tested in industry standards condition. For example electrolytic capacitors are often measured with the Eq ckt series $R_s + C_s$, so ESR (Equivalent series resistance) can be measured up to 25 kHz. This resistance includes parameters such as the absorption and ohmic losses due to connections.

The high value capacitors should be measures at low frequency while low values capacitors are measured with the high frequency.

Regarding inductors, resistance parallel Eq ckt in general represent losses in the core, while the resistance series eq ckt represent resistance of coil.

while the resistance series eq ckt represent resistance of coil.

Heavy inductors are preferably measured with the parallel Eq ckt this case being domination compared to the series resistance. The low values inductors are themselves represented by the series, their reactance being low.

In order to obtain a more accurate result high inductances are analyzed with the lowest rate, while low inductors are analyzed in contrast with the highest.

The instrument can automatically determine Eq ckt generally more appropriate (series impedance below 1000 Ω , parallel over 1000 Ω). But the user can always the ckt of his choice by pressing Eq.Ckt push button key . We can go back to automatic mode selection by a prolonged press on this same key.

The quality factor Q is the ratio of the imaginary part of the impedance and its real part. For inductors, a high value of Q denotes a term better component purity. A value of Q close to zero on the contrary means that the element is close to its resistive strength. Apart from the dissipation in the ohmic resistance of coil. The value of Quality coefficient also depends on the frequency.

The dissipation factor D is commonly used to describe all types of capacitors. It is the opposite of Q, $D = 1/ Q$ and thus represents the relationship between the real part and imaginary of the capacitor or impedance at a given frequency. A low value of D represents a capacitor with low loss.

The measuring principle can be used to measure phase angle between -180° and 180° with a resolution of 0.01° . Measurement of parameters is carried out with an accuracy of $\pm 0.2\%$ basis for components whose value exceeds $Q >10$ ($D <0.1$), which corresponds to a phase shift of approximately $\pm 84^\circ$ (see page precision for details).

It is to be noted that the values obtained when measuring ferro magnetic core windings may be significantly different from their values of use. This is the non-linear behavior of the core towards difference in magnetization between the use and measurement. It is possible to find out the current flowing through winding by measuring the parameters R and X and knowing the source resistance. The source resistance depends on the range; it is 100 Ω for the ranges 1 and 2, for example;

It will

$$i = V_s / \sqrt{((R_s + R)^2 + X^2)}$$

Where $V_s = 0.5 V$ (test voltage)

Example : When measuring a winding , where $R = 2 \Omega$ and $X = 43 \Omega$

The range as determined by the instrument is the range - 2, which has a 100 Ω source

Approx. The current flowing through the winding will be

$$i = 0.5 / \sqrt{((100+2)^2 + 43^2)} = 4.5 \text{ mA}$$

Understanding Displayed Parameters

L + Q Inductance and quality factor : The inductor is displayed on the first line of the LCD. Units of the inductance are H, or μH , mH. Q is the ratio the imaginary part of the impedance and has no unit. The Q value is the same for both types of equivalent circuits (series or parallel). If Q is a positive component is likely inductive or capacitive.

L + AL Inductance and parameter AL : When the mode is selected these parameter replace the parameters L + Q. The value of AL is calculated from the value of inductance and a predetermined number of turns. $L = N^2 \times AL$.

C + D Capacitance and dissipation factor : The capacitance is displayed on the first Line. The units of capacity are pF, nF, μF or mF. D is the ratio of the real part of the impedance to its imaginary part, or $1 / Q$. A good capacitor is with low series equivalent resistance, i.e. with low D. If capacity displayed is negative then the component is inductive.

R + Q : The resistance is either the series resistance (R_s) or parallel resistance (R_p). Units of the resistance are Ω , or $\text{k}\Omega$ or $\text{M}\Omega$, The Resistance is displayed on the first line. Q is displayed in the second line.

|Z| + θ Impedance module and phase angle : The impedance module is shown on the first line. The phase angle is displayed in the second line and is the dephasing between current and voltage at frequency of test. Normally the phase angle is between -90° and 90° for passive components, however, the instrument is capable of measuring

Phase angles between -180.00° and $+179.99^\circ$ (say $+180.00^\circ$). A negative phase angle indicates a capacitive component, while a +ve phase angle indicates a inductive component. The capacitors will have a good phase angle close 90° . A resistance will usually a have phase angle very close to 0° .

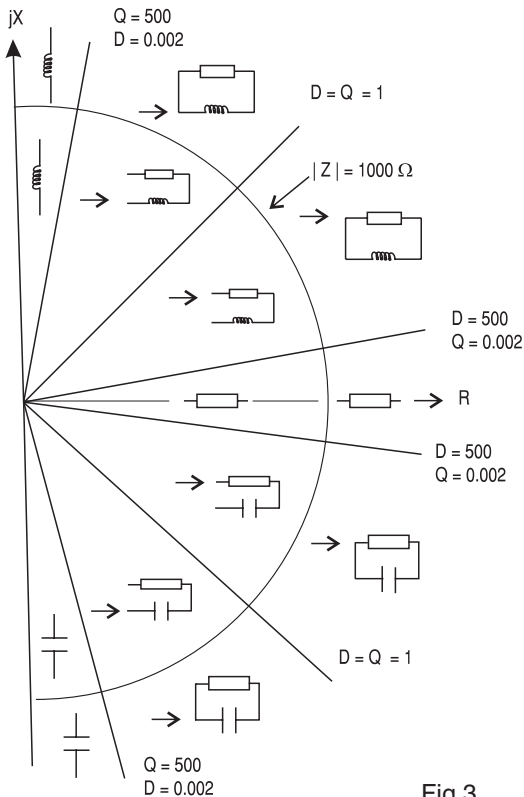

Fig 3

R + X Strength and Reactance : The resistance is displayed on the first line, reactance on the second line. These two values match respectively to the real and imaginary part of the component are expressed in Ω , $k\Omega$ or $M\Omega$.

G + B Conductance and Susceptance : The conductance is displayed on the 1st line and the susceptance in second line. The real part & Imaginary of admittance $Y = 1/Z$, expressed in S or mS μS .

AUTO : Pushing for prolonged, L/C/R/ switch turns instrument to automatic mode. The instrument determines the function that seems most appropriate for certain criteria's summarized in the diagram. When impedance below $10\ m\Omega$ sensed, the resistance functions will be automatically selected.

Note : Large windings with a value of $Q < 1$ will not be automatically detected. The instrument will go in the high resistance. Then increase the frequency of test value to get the value of the Inductor.

Measurement of Transformer Parameters

The instrument has a special function for determining the number of turns between primary and secondary of transformer, the calculation of the secondary voltage of transformer and for estimating / understanding the mutual inductance between the primary and secondary.

The use of this function requires four separate clips connected to four BNC connectors. To use this mode press pushbutton **N / Vs / M**. The transformer primary wires will be connected to HD and LD. The Secondary will be connected to HS and LD. Calibration Open / Closed should not used. The primary winding must be comprising of maximum number of turns. In case of reversing the cables the

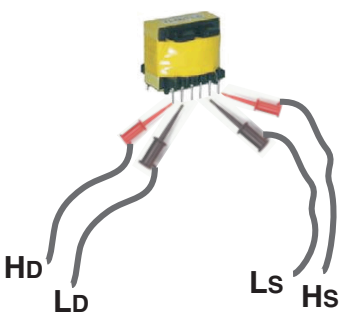

Fig 4

instrument will display the message overflow "OVERFLOW". The instrument has three ranges of measurement according to the value of number of turns. The instrument is set on the first range that allows the most of the measurement. In this the primary voltage range is attenuated by the use of resistance of higher source, which allows greater measuring range of the voltage present at the transformer secondary. The real extent depends on several factors such as the impedance of the transformer primary to the frequency. When testing a transformer one should choose a frequency where the impedance of the primary is less than $100\ \Omega$ to get a measure N^{-1} to 10. A lower value of primary impedance allows to measure higher transformation ratio.

The following parameters are displayed by successive push on the N / Vs / M for the Characterization of processors.

N + θ : The main parameter N is the report of turns ratio between the primary and the secondary winding. The phase shift primary / secondary and the frequency of testing are listed on the second Line.

N⁻¹ + θ : Pressing a second time the key N / Vs / M instrument displays the inverse relationship $N^{-1} = 1/N$.

Range	N ⁻¹	
1	1	... 10
2	0.1	... 1
3	0	... 0.1

Vp +Vs : Primary voltage and secondary voltage. Here instrument will measure secondary voltage based on primary voltage 230V or 115V. Press N / Vs / M Unit the parameters Vp and Vs appear. The primary voltage is 230 V default. To pass in 115V press the Menu button. The second line shows the two options. Press key F1 for 115 V to select the primary voltage as 115 V. The brackets will move under to [115]. Press the button F3 to EXIT and return to the parameters Vs / Vp and instrument will display the secondary voltage for a primary of 115 V this time.

M Mutual inductance

The mutual inductance is measured by measuring the primary current and secondary voltage of transformer. This direct method can be vague to the higher frequencies because of transformer parts. If buffer overflows OVERFLOW message appears. Change then impedance range by Range button. It is advisable to start with the lowest range and then changing to achieve good result. The automatic mode should not be used for this function.

Component Sorting & Binning Function

The instrument allows comparison of components compared to a preset value. The instrument will calculate the difference between the value preprogrammed, which can be displayed in the form of an absolute deviation or percentage.

To access the sorting function press Menu. Press the button F2 for the right arrow (N / Vs / M) until sorting option appears. Enable this function by pressing the F4 key.

To set the percentage of tolerance Menu again, press F2 key for Next option until the desired tolerance is achieved.

Possible values are Auto, 0.1, 0.2, 0.5, 1, 2, 5, 10 and 20%

Press the button on the right arrow.

To enter the nominal value of the component press key for the EDIT option. A cursor appears in the figure. To change the figure press button under the option CHANGE. The figure will increase a unit at each press. To switch to Next digit press NEXT (F1). The cursor will Move to next digit, change the value to obtain the desired value. The unit at the end of the number can also be changed. The options are p (pico, 10^{-12}), n (nano 10^{-9}), μ (micro 10^{-6}), m (mili 10^{-3}), white (as no unit), k (kilo, 10^3), and M (Mega, 10^6). When value is entered press option OK. The entry is now on the first line. Press the button for the right arrow.

In Auto mode sorting function enters into Binning function. Save the menu, the first line on display will show 0.1, 0.5, 1, 2, 5%, when the measurement is done, the value will be displayed, with either of B1, B2, B3, B4 or B5 depending on the values lies in tolerances from 0.1 to 5%.

Setting the alert notification when the measured component satisfies the sort :

The notification is a short beep by default. To change this option press Next option. The options are SHORT (short beep) LONG (beep long), NONE (no beep).

To save the current configuration press YES. The configuration will be stored in memory.

To use the instrument Sort must be configured as a relative measure. In sorting mode the instrument automatically placed in Manual mode freezing the range of impedance underway. You can manually change the range. The Manual mode permits a faster response; the instrument will not seek the range impedance for each measure.

Eq Ckt (Equivalent Circuit) Model Series & Parallel

The push button key Eq Ckt allows you to choose between model SER and PAR. Please also refer to you "Passive Components paragraph" above. When in doubt always use the automatic mode. Press long Eq Ckt push button to override the auto mode function.

DisplayTypes (DISP Push Button)

Users can select three possible display types with successive press of DISP button.

- The measured value
- The difference in value in relation to the current value. The symbol Δ will show next to the Measured parameter indicates that the function is active. If the sorting mode is active message PASS FAIL is displayed on the second line depending on the value of the component, the nominal value and the percentage are defined by the user.
- The difference in percentage compared to the current value. The symbol Δ and unit % indicates that this feature is enabled.

Menu (other functions)

When Menu function is selected , the first row of push button switches , works as F1, F2, F3 and F4 switches . E.g. when left arrow is displayed on display , the function is activated by pressing switch F1 (L/C/R) , for second symbol right arrow , activated by F2 (N/Vs/M) and for next two functions, activated by F3(Freq) , F4(Range) respectively.

Menu	By Default Value	Function
Sound	ON	Activation buzzer
Averaging	ON	averaging activation
Numb Avrg.	4	Number of values for the average
User F	1.25 kHz	User selectable Frequency
Sorting and	OFF	Use this function to sort Components. 1- When this feature is enabled the user can determine the percentage, The nominal value and the type of data in out of tolerance. 2- Press F2 to move to setting tolerance. F3 and F4 gives setting tolerance limits from 0.1% to 20 % in steps. When done press Menu to exit.

- 3- For setting nominal value for sorting , press F2 once again after step 1 discussed above. This will display Value option, press F3 to edit . Press F1(NEXT) for moving cursor,F2 (CHANGE) for changing values at cursor position from 0 to 9 , even units can be changed to m, k, M etc. F3 (OK) to confirm the value set. Press Menu to exit.
- 4- Press the right arrow (F2), which can validate when a component meets previously defined limits.
NONE : Buzzer inactive in sorting.
SHORT : Short beep when the value of the component is in the range
LONG : Deep long under the same conditions.
- 5- Press MENU key, which allows to save the configuration settings in non-volatile memory.
- 6- To use the instrument place Sort mode Relative (use through DISP button).
- 7- To disable mode sorting . Press MENU and select SORTING OFF. Press the Menu button and then save.

Measure AL Off

Press F4 to select, press F2 to enter the number of turns of wire rolled up on the bobbin. NEXT (F1) will select cursor , CHANGE (F2) will select value change from 1 to 999 , OK (F3) to confirm. To get precise, it is advised to achieve at least 10 turns uniformly spread over the bobbin.

When this feature is enabled instrument displays value [L + AL] instead of Normal [L + Q] mode. To return to normal mode select this Option.

Zero Compensation or OPEN / SHORT calibration

Zero compensation or open-short calibration function of the instrument can compensate for the parts of the measuring cable in order to compensate for parasitic elements. The model used is the one represented in the figure below.

The instrument determines the value of these elements R_{ss} and L_{ss} at a preliminary measure.

The values of G_{pp} and C_{pp} are measured during open circuit measure. The instrument reflects these elements by applying the correction given on the diagram. The calibration should be carried out each time that there is measures at the ends of the measuring range, which means for the weak and high impedances. Calibration open/closed is also essential if we are to the reduce margin of error losses in a measured value of component. Such as the resistance of a series capacitor. Precautions should be taken during the calibration. The position of cables should not change between the calibration and measurement of the component. During the shorted calibration it should be a small piece wire that connects the four jaws of clip, or both clamps. For very low impedance values place component in clips at 90° to minimize coupling between wires as shown in the figure. The same Provision should be used when measuring a component.

The calibration can be performed for a frequency of Test data or for all the frequencies. Indeed, the parts are not necessarily consistent with all the frequencies, and the instrument retains in memory parasites elements for all four fixtures for each frequency. Calibration is performed pressing CAL. A menu appears, and you can make a choice Calibration Shorting (Short) or open circuit (open). The limits of correction are:

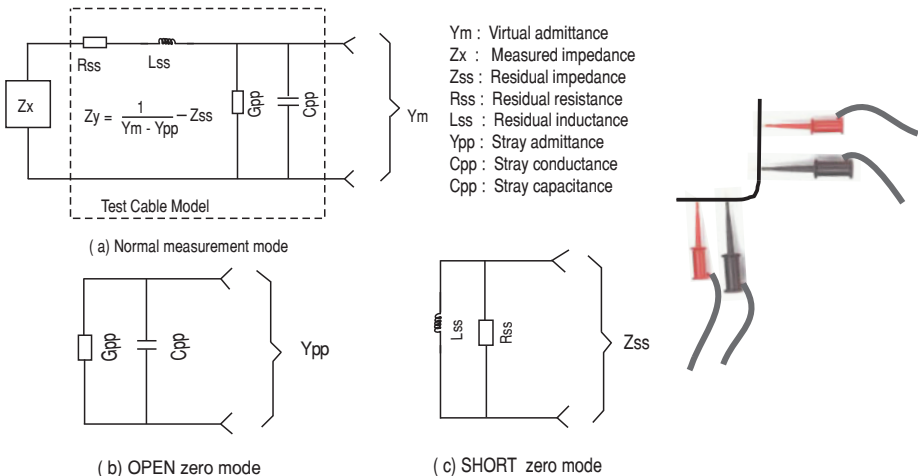

Fig 5

- Calibration short : maximum series resistance of the cables must be less than $8\ \Omega$ while the total impedance should be less than $8\ \Omega$.
- Calibration open : parallel impedance of the cable must be more than $1\ M\Omega$.

The instrument displays the zero readings after adjustment or near zero value , except for small negligible value (to be ignored , part of value too small in comparison to the range) if the calibration went well, “Failed” in the opposite case.

To perform a calibration at all frequencies press CAL for long instrument displays the menu “OPEN SHORT” in capital letters. The instrument then launches the procedure for calibration at all frequencies, which takes little more time to complete. Calibration must be preformed at each change of measures cord or for sensitive measures (see above). Calibration in open circuit is more delicate because the spacing of contacts varies.

Frequency of Test

There are 11 possible test frequencies ; 100 Hz, 120 Hz, 250 Hz, 500 Hz, 1.0 kHz, 2.5 kHz, 5 kHz, 7.8 kHz, 12.5 kHz, 15.6 kHz and 25 kHz. An additional frequency can be User-defined with more than 500 possible frequencies between 100 Hz and 25 kHz. The Frequency accuracy is 0.01% (100 ppm). The frequency of current test can be changed by pressing Freq push button. The frequency is indicated to the right of the second line. The frequency of the test 1 kHz is used mostly. It is the frequency for which accuracy of the instrument is optimal. The capacitors and coils higher values are tested with the lowest frequency, while the low capacity and Low inductors are measured with a higher frequency. The wide range of frequency allows for example the test of audio processors throughout the Audible spectrum. The frequency of 120 Hz should not be used when the instrument is configured for a frequency of 50Hz sector, the same frequency of 100 Hz should not used to be a frequency of 60 Hz sector. The user frequency allows user to choose a desired frequency accurately. To see or modify this frequency press the MENU key. Select User “f” with the buttons F1 and F2 , and F3 to edit. To change the frequency press F3, use F1 for cursor movement and F2 for changing the value. Once done press F3 , the nearest user frequency will be set according to the following formula.

$$F = 125\ \text{kHz} / (N1 \times N2)$$

The maximum limit is 25 kHz obtained for $N1 = 5$ and $N2 = 1$. The lower limit functional is about 90 Hz $N1$ can be adjusted between 2 and 255. $N2$ may take the values 1, 2, 4, or 8.

Note : The instrument makes an extrapolation (extrapolation is the process of constructing new data points outside a discrete set of known data points. It is similar to the process of interpolation, which constructs new points between known points) of calibration coefficients when measurement is made with user frequency. The accuracy can thereby alter.

Impedance Range

The Instrument has 6 impedance ranges (R1-R6). The range of impedance can be selected manually or can be set to automatic, which is the normal or default mode. Range in use is indicated on left in 2nd line with word A or H (Flashing) meaning auto or manual. Pressing push button Range button activates automatic mode and reverse. Pressing button allows freezing the current range. Successive press allows choosing the desired range. The table below shows the limits impedances for each of the ranges. F is the Test frequency expressed in kHz. The ranges R1 and R6 ranged are extended, they use resistors respectively reference ranges R2 and R5.

Note : The ranges are impedances ranges, and not capacities or Inductor. The choice of a manual range implies on knowing the impedance of the component under testing. The manual mode will be restricted when measuring similar components whose impedance is know. And does not vary too much. Otherwise the instrument should be configured for automatic mode. The choice of range not suitable impedance will result in an unstable or by displaying the message "OVERFLOW" error.

Range	R source	Resistance	Inductance(H)	Capacitance
R1	100 Ω	1 m Ω -10 Ω	0.01 μ H-2.4/f	99.9mF-10.6/f mF
R2	100 Ω	10 m Ω -330 Ω	2.4/f-52.5/f	10.6/f mF-482/f μ F
R3	1.1 k Ω	330 Ω -3.3 k Ω	52.5/f-525/f	482/2f μ F-48.2/f μ F
R4	11.1 k Ω	3.3 k Ω – 33 k Ω	525/f-5252/f	482/2f μ F-4.82/f μ F
R5	111 k Ω	33 k Ω – 800 k Ω	5252/f-52520/f	4.82/2f μ F-0.48/f μ F
R6	111 k Ω	800k Ω -100M Ω	52520/f-99990	48/f μ F-0.001/f pF

Here f is frequency in Hz

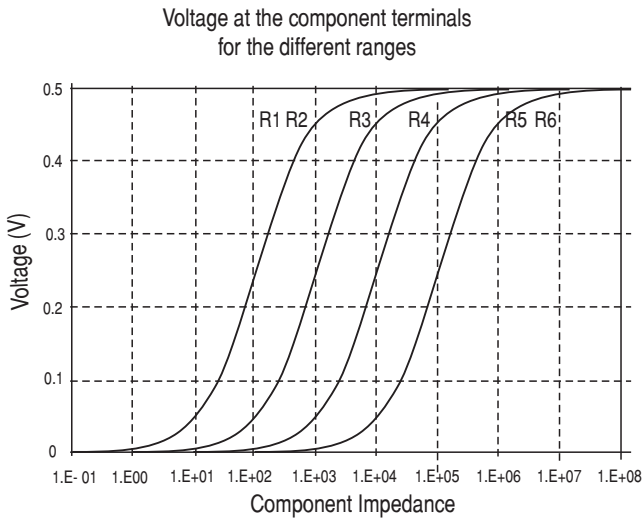

Fig 6

The source resistance of the signal generator test is linked to the range as shown in Table (R SOURCE column). The real test voltage within the leads of Component depend on the range and its impedance as shown in the chart below

Precision and Accuracy

The accuracy of measurements depends on the basic accuracy which depends on the value of the impedance and frequency, This value is increased by a factor corresponding to additional impedance that can be found at the ends of measuring clips. The values of accuracy are valid with the use of a Kelvin cable, where calibration open/closed is carried out before the measure and when the instrument is in automatic mode.

Precision Resistors and Impedances

Accuracy of Resistance :

$$Ar = \pm [Ae + (KH+KL) \times 100] \%$$

Ae: basic accuracy value in the graph below. For values of Q > 0.1 multiply the value of A by (1+|Q|)

KH, KL factors corresponding to the error at the ends of lines.

$$K_L = 1 \text{ m}\Omega / R_m.$$

$$K_H = R_m / 1 \text{ G}\Omega$$

K_H is negligible for the resistance less than 50 k Ω

K_L is negligible resistance for more than 20 Ω

Accuracy of Q :

$$Q_e = (A_r/100) (1+Q \times 2)$$

With A_r accuracy of the resistance calculated above

Calculation example :

Calculate the accuracy of the measurement of resistance of 1 k Ω at 1 kHz. The measurement gives a Value of $Q = Q_x = 0.0005$

From the graph there is a basic accuracy of 0.2% = A_e

$$K_L = 1 \text{ m}\Omega / 1 \text{ k}\Omega = 10^{-6}$$

$$K_H = 1 \text{ k}\Omega / 1 \text{ G}\Omega = 10^{-6}$$

$$\text{Accuracy of resistance} = \pm (0.2 + 0.0002)\% \pm 0.2\%$$

Accuracy Q:

$$\Delta Q = (0.2/100) \times (1 + 0.00052) = 0.002$$

Accuracy of Inductors :

Accuracy of L :

$$A_I = \pm [A_e + (K_H + K_L) \times 100] \%$$

A_e : Basic accuracy value in the graph below. For values of $Q > 0.1$ multiply the value of A by $(1+|Q|)$

K_H , K_L factors corresponding to the error at the ends of lines.

$$K_L = 0.16 \mu\text{H} / (L_m \times f)$$

$$K_H = (L_m \times f) / 160 \text{ kH}$$

F : Frequency test in kHz

Accuracy of Q :

$$Q_e = (A_I/100) (1+Q \times 2)$$

With A_I accuracy of the calculated above inductor,

Note: The accuracy is a quality Q is absolute and not a percentage.

Accuracy of Capacitor :

Accuracy C :

$$A_c = \pm [A_e + (K_H + K_L) \times 100]\%$$

A_e : basic Accuracy value in the graph below. For values of $Q > 0.1$ multiply the value of A by $(1 + |Q|)$

K_H , K_L factors corresponding to the error at the ends of lines

$$K_L = 0.16 \text{ pF}/(\text{cm} \times f)$$

$$K_H = (\text{cm} \times f)/160 \text{ mF}$$

F : Frequency test kHz

Accuracy Q

$$Q_e = (A_c/100) (1 + Q \times 2)$$

With AI accuracy of the capacity calculated above

Note: The accuracy is a quantity Q is absolute and not a percentage.

Basic Accuracy and Graph

The accuracy of a **LCR meter** is quite complex. The basic accuracy is a Fig 7, depending of the actual test frequency and absolute impedance, from which the final accuracy is calculated. This figure is given by a two-dimensional graph. The actual accuracy is always less than the basic accuracy; it is equal for medium impedances and decreases when the impedance is getting low or high. The test fixture causes this effect, which is never perfect. Parasitic series impedance and parallel impedance are not constant, so for extreme impedances there are more errors. This is the same for all **LCR meter**. When one says that the basic accuracy is 0.2 % it is valid for a maximum frequency (always 1 kHz) and for given range of impedance (generally from 1 ohm to 1 M ohm). The better basic accuracy is limited by the accuracy of calibration resistors, and the drift of reference resistors inside the instrument.

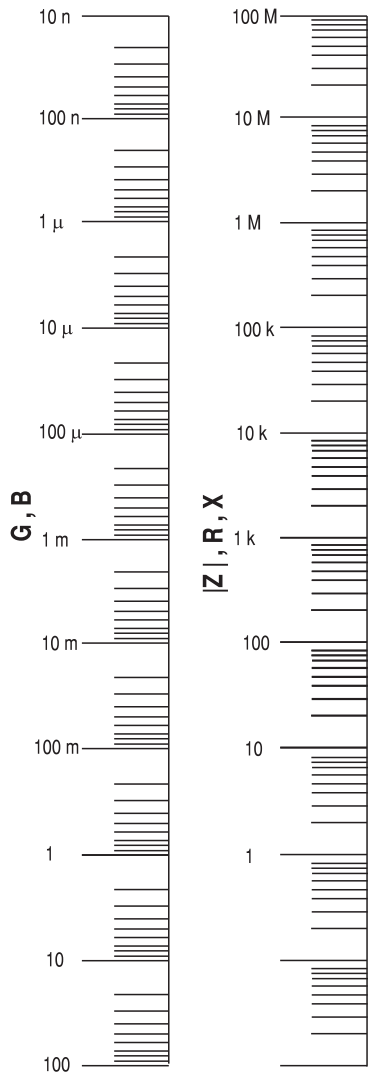

Fig 7

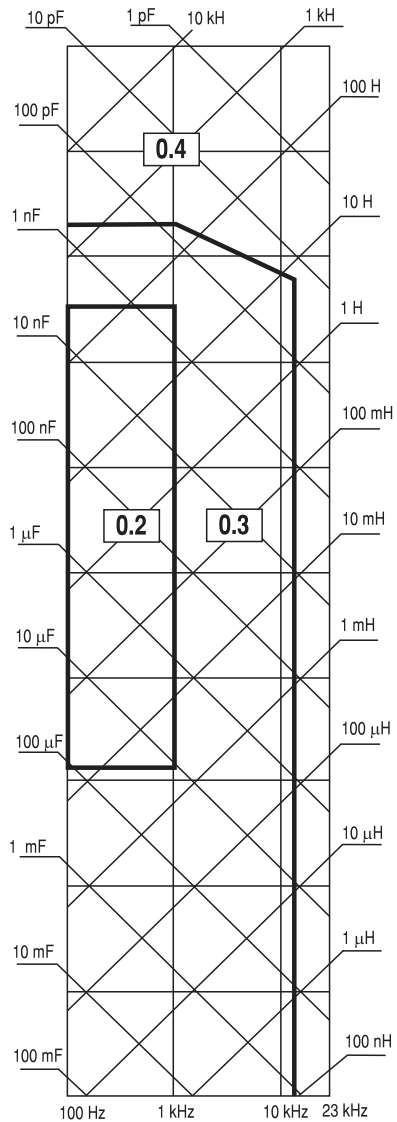

Fig 9

Basic Accuracy Graph

Maintenance

There are no user serviceable part inside **SM6019**. Your **SM6019** LCR Meter is thoughtfully engineered for ease of use, accuracy and reliability. The instrument is carefully tested and calibrated using standards traceable to National Laboratories.

Take care of your instrument by cleaning the exterior of the instrument regularly with a dusting brush. Dirt which is difficult to remove on the casing & plastic parts, can be removed with a moist cloth (99% water, 1% mild detergent) spirit or washing benzene(petroleum ether) can be used to remove greasy dirt. The display may be cleaned with water or washing benzene (but not with spirit-alcohol solvents), it must then be wiped with a dry clean lint-free cloth. Under no circumstances the cleaning fluid should get into the instrument. The use of cleaning agents can attack the plastic & paint surfaces.

Power Line Fuse Replacement

The power line fuse is located on rear panel on lower right side. In case, the instrument does not show any sign of working, no LCD is lit or there is no display immediately switch OFF the mains power switch of the instrument and unplug the mains cord from the mains socket.

With the help of small flat blade screwdriver remove the fuse cap of the fuse holder, located just below the socket. There is one spare fuse kept in the fuse cap, replace it for the defective one. Turn the cap so that it locks in place . The rating of the fuse is 150 mA , 250 V , sloblo , 5x20 mm glass fuse. Do not use a fuse with a higher value other wise it may damage the instrument in case, the mains voltage goes much higher than the rating of the mains fluctuation of $\pm 10\%$.

Despatch Procedure for Service

No user serviceable parts are inside the instrument , should it become necessary to send back the instrument to factory for service ,please observe the following procedure.

Before despatching the instrument please write to us giving full details of the fault noticed.

- 1.After receipt of your communication, our service department. will advise you whether it is necessary to send the instrument back to us for repairs or the adjustment is possible in your premises.
- 2.Despatch the instrument (only on the receipt of our advise) securely packed in original packing duly insured and freight paid along with accessories and a copy of the faults details noticed at our Service Center listed on last page of this manual, nearest to you.

Warranty Conditions

1. Scientific warrants all its Instruments to be free from defects in material and workmanship when used under normal operating conditions in accordance with the instructions given in the manual for a period of 12(Twelve) months from date of purchase from Scientific or its authorised dealers. The service during the warranty period will be rendered on return to factory /service center basis.
2. Its obligation under this warranty is limited to repairing or replacing at its own discretion. This warranty shall not apply to any defect, failure or damage caused by accident, negligence, mis-application, alteration or attempt to repair, service or modify in any way.
3. This warranty does not include LCD, fuses, batteries or accessories. This warranty is only valid with the original purchaser who must have properly registered the product within 15 days from date of purchase. No other warranty is expressed or implied.
4. When it becomes necessary to return the instrument to our Factory facility, kindly pack it carefully in the original carton or equivalent and ship it duly insured, transportation charges prepaid.
5. Your Scientific instrument is a complex electronic device and deserves the best service available by technicians thoroughly familiar with its service and calibration procedures.

Major Service Centers

Phone / Fax / Email

1. Scientific Mes-Technik Pvt. Ltd.,
29/3/E, Snehlata Ganj ,
Indore M. P. 452 003
Ph : (0731) 2309741,2422330-31
Fax :(0731)2422334, 2561641
info@scientificindia.com
2. Scientific Mes-Technik Pvt. Ltd.,
B-13, D.S.I.D.C Packging Complex
Kirti Nagar, New Delhil 110 015
Ph : (011) 65638100, 65638101
Fax:(011)26536298
ndelhi@scientificindia.com
3. Scientific Mes-Technik Pvt. Ltd.,
NO. 46, 4 th Main Cross ,
MLA Layout,
R. T. Nagar, Bangaluru 560 032
Ph : (080) 23437635
Fax:(080)23331478
bangalore@scientificindia.com
4. Scientific Mes-Technik Pvt. Ltd.,
No. 25 , 2 nd floor,
29 th Cross Street
Indira Nagar, Adyar
Chennai 600 020
Ph : (044) 24424598
Fax :(044) 24420421
chennai@scientificindia.com
5. Scientific Mes-Technik Pvt. Ltd.,
Room No. 308, Building No.2,
3rd Floor, Sundar Nagar
Co-op. Hsg Society Ltd.
Senapati Bapat Marg, Dadar (W)
Mumbai 400 028
Ph. :(022) 24211171
Fax :(022)24333654
mumbai@scientificindia.com
6. Scientific Mes-Technik Pvt. Ltd.,
209, Lloyd's Chamber III
409, Mangalwar Peth,
Maldhakka Chowk ,
Pune 411 011
Ph. : (020)26114688
Fax : (020)26132882
pune@scientificindia.com
7. Scientific Mes-Technik Pvt. Ltd.,
"Krupa Ashirwad Complex",
2nd Floor, Door No.5-2-394 81/A,
R.P. Road, Hyderbasti
Secunderabad 500026
PH : (040)27534995
Fax : (040)27534996
hyderabad@scientificindia.com
8. Scientific Mes-Technik Pvt. Ltd.,
13/A/1, Civil Line, Kanpur Road
Near Vivekanand Crossing
Allahabad (U.P.)
PH : (0532)2260833
allahabad@scientificindia.com
9. Scientific Mes-Technik Pvt. Ltd.,
2, Chowringhee Road,
Kolkata 700 013
Ph : (033) 2228 2223-6
Fax : (033)2228 1713
kolkata@scientificindia.com

