

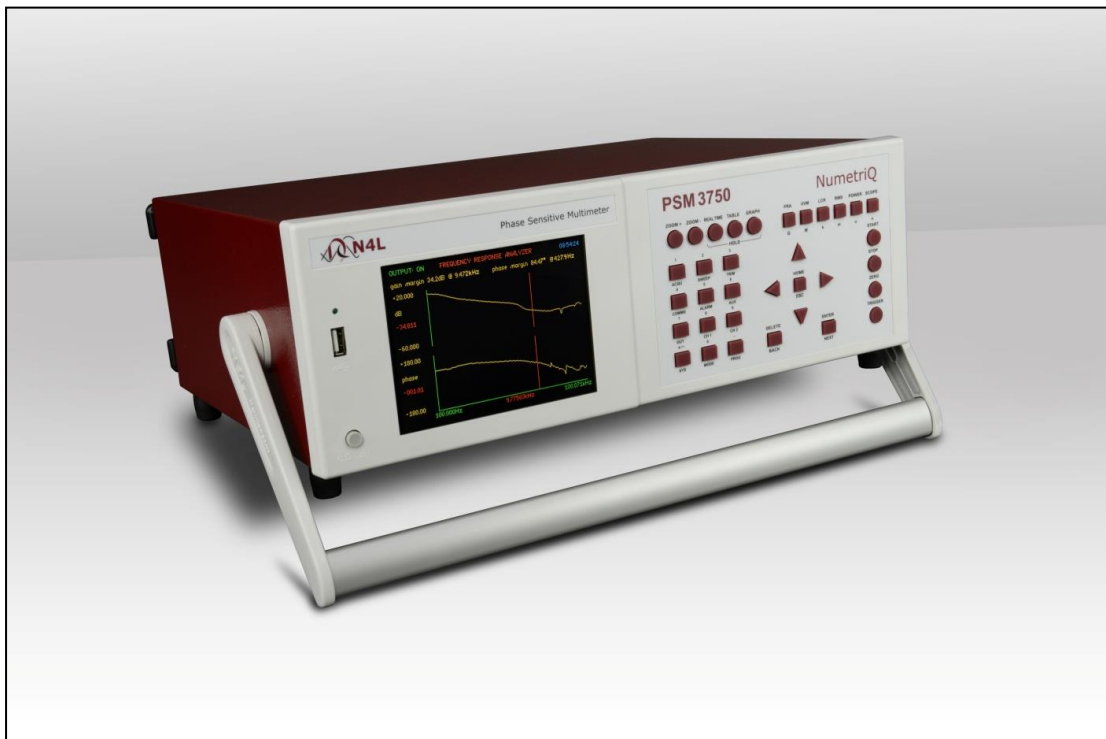

N4L Newtons4th Ltd

PSM3750

User Manual



This manual is copyright © 2006-2021 Newtons4th Ltd. and all rights are reserved. No part may be copied or reproduced in any form without prior written consent.

Document Title: PSM3750 User Manual v3.1

Document Release Date: 14th July 2021

PSM3750 Firmware version on release date: v2.49

Document Ref: D000266 issue 04

"Do not be hasty when making measurements."

The PSM3750 is a precision instrument that provides you with the tools to make a wide variety of measurements accurately, reliably, and efficiently - but good metrology practice must be observed. Take time to read this manual and familiarise yourself with the features of the instrument in order to use it most effectively.



DANGER OF ELECTRIC SHOCK

Only qualified personnel should install this equipment, after reading and understanding this user manual. If in doubt, consult your supplier.



RISQUE D'ELECTROCUTION

L'installation de cet équipement ne doit être confiée qu'à un personnel qualifié ayant lu et compris le présent manuel d'utilisation. Dans le doute, s'adresser au fournisseur.



GEFAHR VON ELEKTRISCHEM SCHOCK

Nur entsprechend ausgebildetes Personal ist berechtigt, diese Ausrüstung nach dem Lesen und Verständnis dieses Anwendungshandbuches zu installieren. Falls Sie Zweifel haben sollten, wenden Sie sich bitte an Ihren Lieferanten.



RISCHIO DI SCARICHE ELETTRICHE

Solo personale qualificato può installare questo strumento, dopo la lettura e la comprensione di questo manuale. Se esistono dubbiconsultate il vostro rivenditore.



PELIGRO DE DESCARGA ELÉCTRICA

Solo personal cualificado debe instalar este instrumento, después de la lectura y comprensión de este manual de usuario. En caso de duda, consultar con su suministrador.

IMPORTANT SAFETY INSTRUCTIONS

This equipment is designed to comply with BSEN 61010-1 (Safety requirements for electrical equipment for measurement, control, and laboratory use) – observe the following precautions:

- Ensure that the supply voltage agrees with the rating of the instrument printed on the back panel **before** connecting the mains cord to the supply.
- This appliance **must** be earthed. Ensure that the instrument is powered from a properly grounded supply.
- The inputs and outputs must not be connected to common mode signals greater than 500V peak.
- The inputs must not be connected to signals greater than 500V peak.
- Keep the ventilation holes on the underneath and sides free from obstruction.
- Do not operate or store under conditions where condensation may occur or where conducting debris may enter the case.
- There are no user serviceable parts inside the instrument – do not attempt to open the instrument, refer service to the manufacturer or his appointed agent.

IMPORTANT SAFETY NOTICE

Input Connections:

It is critical that the 4mm inputs and BNC inputs on each PSM input channel are not connected to any external circuit at the same time.

You MUST only use EITHER the 4mm OR the BNC connection – NOT both, this applies to both Voltage and Current inputs.

Note: Newtons4th Ltd. shall not be liable for any consequential damages, losses, costs or expenses arising from the use or misuse of this product however caused.

DECLARATION OF CONFORMITY



Manufacturer: Newtons4th Ltd.
Address: 1 Bede Island Road
Leicester
LE2 7EA

We declare that the product:

Description: Phase Sensitive Multimeter
Model: PSM3750

Conforms to the EEC Directives:

2014/30/EU relating to electromagnetic compatibility:
EN 61326-1:2013

2014/35/EU relating to Low Voltage Directive:
EN 61010-2-030:2010:

July 2021

Jigar Patel
(Senior Engineer, Newtons4th Ltd.)

WARRANTY

This product is guaranteed to be free from defects in materials and workmanship for a period of 36 months from the date of purchase.

In the unlikely event of any problem within this guarantee period, first contact Newtons4th Ltd. or your local representative, to give a description of the problem. Please have as much relevant information to hand as possible – particularly the serial number and release numbers (press SYSTEM then LEFT).

If the problem cannot be resolved directly then you will be given an RMA number and asked to return the unit. The unit will be repaired or replaced at the sole discretion of Newtons4th Ltd.

This guarantee is limited to the cost of the PS3750 itself and does not extend to any consequential damage or losses whatsoever including, but not limited to, any loss of earnings arising from a failure of the product or software.

In the event of any problem with the instrument outside of the guarantee period, Newtons4th Ltd. offers a full repair and re-calibration service – contact your local representative. It is recommended that the PSM3750 is re-calibrated annually.

Calibration note:

- Performance test specification available from N4L upon request.
- If calibrating with Fluke 6105A, refer to brochure for test specification accuracy between 40~450Hz.

ABOUT THIS MANUAL

The PSM3750 has a number of separate measurement functions that share common resources such as the keyboard and display.

Accordingly, this manual first describes the general features and specification of the instrument as a whole; and then describes the individual functions in detail.

Each function is described in turn, in its own chapter, with details of the principles on which it is based, how to use it, the options available, display options, specifications etc.

Detailed descriptions of the RS232 command set are given in the separate manual "PSM3750 communications manual".

PSM3750 user manual

CONTENTS

1	Introduction – general principles of operation	1-1
1.1	Generator output	1-4
1.2	Voltage inputs	1-5
1.3	Analogue inputs.....	1-6
2	Getting started	2-1
2.1	Unpacking.....	2-1
2.2	Keyboard and controls.....	2-4
2.3	Basic operation	2-5
2.4	Measurement Selectivity	2-6
3	Using the menus.....	3-1
3.1	Selection from a list	3-3
3.2	Numeric data entry	3-4
3.3	Text entry	3-5
4	Special functions.....	4-1
4.1	Display zoom.....	4-1
4.2	Program store and recall.....	4-2
4.3	Zero compensation.....	4-3
4.4	Alarm function	4-4
4.5	Analogue output	4-6
4.6	Data hold.....	4-7
4.7	Results store and recall.....	4-8
5	Using remote control	5-1
5.1	Standard event status register.....	5-4
5.2	Serial Poll status byte	5-5
5.3	RS232 connections.....	5-6
6	System options.....	6-1
6.1	User data	6-3
7	Measurement options.....	7-1
7.1	ACQU - Acquisition options.....	7-1
7.2	Datalog.....	7-4
7.3	SWEEP - Frequency sweep options	7-6
7.4	TRIM - Trim function	7-7

PSM3750 user manual

8	Output control	8-1
8.1	Generator specifications.....	8-3
9	Input channels.....	9-1
9.1	Trimming x10 oscilloscope probes	9-5
10	True RMS Voltmeter	10-1
10.1	RMS voltmeter specification.....	10-5
11	Frequency response analyser	11-1
11.2	Quick start guide to Feedback Loop Analysis.....	11-5
12	Phase angle voltmeter (vector voltmeter)	12-1
12.1	Phase angle voltmeter specification	12-4
13	Power meter.....	13-1
13.1	Power meter specification	13-5
14	LCR meter.....	14-1
14.1	Nyquist Diagram	14-7
14.2	LCR meter specification	14-9
15	Harmonic analyser	15-1
15.1	Harmonic analyser specification	15-4

PSM3750 user manual

APPENDICES

- Appendix A Accessories
- Appendix B Serial command summary
- Appendix C Available character set
- Appendix D Configurable parameters
- Appendix E Environmental Specification
- Appendix F Contact details

1 Introduction – general principles of operation

The PSM3750 is a self-contained test instrument, with one output and two or three inputs, which incorporates a suite of test functions.

The PSM3750 has a wide bandwidth, isolated, generator output that can be used as signal generator for sine, square, triangle, or sawtooth waveforms, or true white noise. A dc offset may be added to the signal generator output. The output is fully isolated from earth to 600Vpk cat II.

The PSM3750 has two or three isolated, high bandwidth, voltage inputs, which use direct digital analysis at low frequencies and a heterodyning technique to give high accuracy at high frequencies. The inputs are fully isolated from each other and from earth to 600Vpk cat II.

The PSM3750 has two processors:

- a DSP (digital signal processor) for data analysis
- a CPU (central processing unit) for control and display

At the heart of the system is an FPGA (field programmable gate array) that interfaces the various elements, see diagram below:

PSM3750 user manual

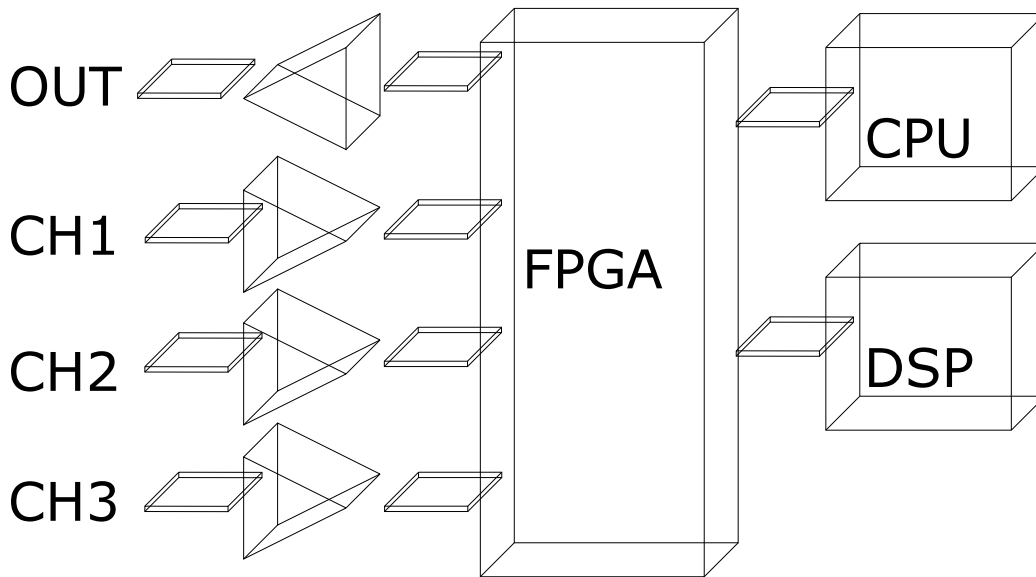

This general-purpose structure provides a versatile hardware platform that can be configured by firmware to provide a variety of test functions, including:

- Signal generator
- Two channel true rms voltmeter
- Phase angle voltmeter (vector voltmeter)
- Frequency response analyser (gain/phase analyser)
- Harmonic analyser

With additional external interfaces, such as current shunts, other functions are possible:

- True rms current meter
- LCR meter
- Power meter

The PSM3750 is configured to perform the required test function by simple user menus or can be controlled remotely via a serial interface (RS232), or optionally LAN interface or GPIB interface.

PSM3750 user manual

The programmable nature of the instrument means that new functions can be added as they become available, or existing functions can be enhanced, by simple firmware download.

1.1 Generator output

The output sinewave is generated by direct digital synthesis (DDS). Amplitude is set in 2 stages - a fine control and a coarse control to give good resolution over the whole range. The output, has a variable offset added, is filtered and is buffered by a high speed, high current buffer. There is also an earth referenced TTL Sync output for oscilloscope synchronization etc, constantly running at the selected generator frequency.

The DDS is clocked at 210 MHz.

The DAC resolution is 14 bit.

The fine amplitude control is 10 bit (0.1% fsd).

The coarse amplitude control is 4 bit.

The maximum output level is $\pm 10\text{V}$ peak.

The maximum output current is $\pm 200\text{mA}$ peak.

The 0V of the output is isolated from earth.

The output impedance is 50Ω .

The output frequency range is 10uHz to 50MHz.

The Sync output is TTL level at generator frequency.

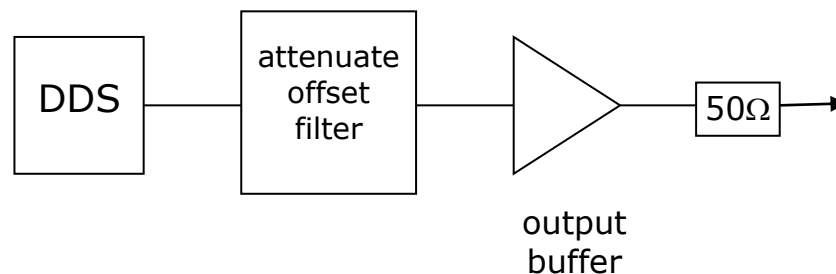

1.2 Voltage inputs

Each input consists of a pair of ac, or ac+dc, coupled high impedance buffers, one for the high voltages and one for lower voltages. The BNC safety connector and 4mm safety connectors are in parallel – either connector may be used.

After the selectable heterodyning and filtering, there is a series of gain stages leading to an A/D converter. The data from the A/D is transmitted across an isolation barrier to the DSP. Selection of the input gain, the heterodyning and the sampling of the A/D converter are under the control of the DSP. There is an autozero switch at the front end for dc accuracy.

The maximum input is $\pm 500V$ peak.

The full scale of the lowest range is $\pm 3mV$ peak.

The input frequency range is dc to 50 MHz.

The A/D converter resolution is 14 bit.

The A/D sample rate is variable to 1M samples/s.

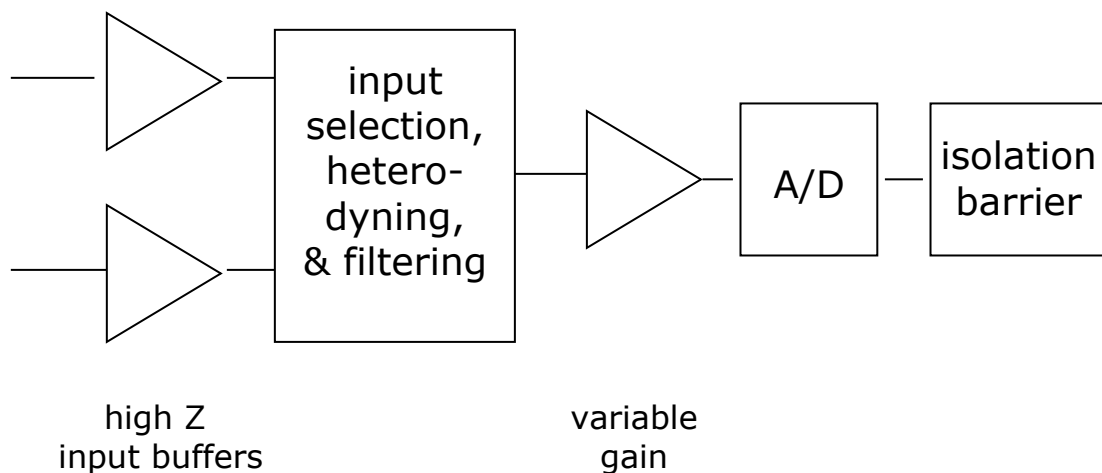

1.3 Analogue inputs

The temperature can be monitored while in LCR mode by connecting a suitable temperate sensor to first Analogue input "I/P 1". The input accepts an analogue from -10V to +10V which can be scaled by an offset and a factor in degrees per volt. The offset is entered as the zero-degree voltage so for a sensor with an output range of $5^{\circ} / \text{Volt}$ and $0\text{V} = 10$ degrees, the offset to be entered would be -2V.

2 Getting started

The PSM3750 is supplied ready to use – it comes complete with an appropriate power lead and a set of test leads. It is supplied calibrated and does not require anything to be done by the user before it can be put into service.

2.1 Unpacking

Remove the instrument and accessories from the packaging and check them against the supplied packing list. Please contact your N4L office or local sales distributor should any items found to be missing or damaged during transportation.

Please retain the original packaging to ensure easy and safe return of the equipment for calibration etc.

If rack mounting brackets have been fitted to the equipment, please remove them before packaging the equipment for return. This reduces the risk of damage to the equipment during transportation.

Having verified the contents against the packing list, it would be wise to verify that your PSM3750 operates correctly and has not been damaged in transit.

First verify that the voltage rating on the rear of the PSM3750 is appropriate for the supply, then connect the mains cord to the inlet on the rear panel of the PSM3750 and the supply outlet.

Switch on the PSM3750. The display should illuminate with the model name and the firmware version for a few seconds while it performs some initial tests.

PSM3750 user manual

After the tests, the instrument will display a message letting the user know that the high voltage protection mode is enabled. The High Voltage Protection feature disables autozero if any of the channels shows a measurement of 100 volts or above.

The user will need to press the HOME button to begin measurements. The user can disable the protection message and begin measurements at powerup by setting the "Begin measurements on Powerup" in the SYSTEMS OPTIONS menu to ON. This however, will not disable the high voltage protection mode.

Note that the switch on message can be personalised – see the User Data section under System Options. The generator is off by default so the display may read some random values due to noise pick up. Connect the Red and Black output leads to the 4mm output sockets on the rear of the PSM3750 and input probes to the BNC on each of the input channels. Connect the output to all the inputs by connecting the black clip on the output lead to the 0V clip on each of the input probes, and the red clip of the output lead to the input probes. Note that this is easiest to do by connecting across a resistor (any value above 1k).

Press the OUT key to invoke the output menu, then press the UP key to select the output on/off control then the RIGHT key to turn on the output by selecting "on".

Exit the menu by pressing the ENTER button or the HOME button *twice*.

The display should now indicate a magnitude value of about 1.4V on all channels, each of which should indicate the 3V range; check that the gain reads 0.000dB \pm 0.010dB, and that the phase reads 0.000° \pm 0.010°.

PSM3750 user manual

In the event of any problem with this procedure, please contact customer services at Newtons4th Ltd. or your local authorised representative: contact addresses and telephone numbers are given in the appendix at the back of this manual.

2.2 Keyboard and controls

The keyboard is divided into 5 blocks of keys:

- display control (5 keys top left)
- function keys (6 keys top right)
- setup keys (12 keys lower left)
- menu control keys (7 centre keys)
- action keys (4 keys lower right)

In normal operation, the cursor keys give one-touch adjustment of various parameters, such as generator amplitude and frequency, without having to access the menu system.

The setup keys provide access to the menus and are used for numeric data entry.

The function keys (FRA, PAV, LCR, RMS, POWER and SCOPE) are also used for entering the multipliers (G, M, k, m, u, n) for data entry and letters for text entry.

2.3 Basic operation

The required function can be selected by pressing the function key, FRA, PAV, LCR, RMS, POWER, or SCOPE. Pressing the same function key again brings up the menu options specific to that function. For example, press PAV to select phase angle voltmeter mode; press PAV again to gain access to the PAV specific menu options.

Alternatively, press MODE to bring up the function specific menus.

There are a number of menus available to configure the instrument. All of these menus are directly accessible with one press of the appropriate menu key. The cursor keys allow navigation around the menus and also control the generator when not accessing a menu.

For example, to turn on the output, press OUT to bring up the generator control menu, press UP to select the output on/off option, press RIGHT to select the output from the available options. Press ENTER, or HOME twice, to exit the menu. Press FRA to select frequency response analyser mode and the instrument will now display the gain and phase of the transfer function of the circuit under test at the spot frequency specified by the output control menu.

Press LEFT or RIGHT to adjust the frequency, Press UP or DOWN to adjust the amplitude (use the OUT menu to change the size of the steps).

Press START and the PSM3750 will start a frequency sweep over the specified range (set in the SWEEP menu); press TABLE to see the table of results, GRAPH to see a graph of the results and REAL TIME to return to the real time data.

2.4 Measurement Selectivity

In many applications that require frequency response analysis, it is common for the frequency of interest (sometimes referred to as the injected frequency) to be immersed in noise. It is therefore important that the FRA instrument being used is able to reject frequencies other than that of the signal of interest. This feature is usually described as the **measurement selectivity** of the instrument and in most cases; selectivity is increased as the measurement speed is slowed down.

N4L frequency response analysers incorporate analogue circuits with high common mode rejection and unique 'real time' DFT (discrete fourier transform) analysis to provide exceptional wideband frequency response measurements even when the signal of interest is immersed in noise. As a result of this design technique, users are not required to concern themselves with the careful choice of selectivity criteria to achieve stable measurements.

In most applications, the signal of interest is generated by the FRA itself. When using this normal mode of operation, PSM units from N4L will automatically analyse the measurement signal with a DFT algorithm running at exactly the same frequency as the injected signal. This process eliminates the problem of signal frequency detection.

Where an external signal source is used for signal injection, the PSM units will detect the injected frequency with a greater level of selectivity as the measurement speed is slowed down. The user need only select the measurement speed to achieve the optimum balance of speed and measurement stability.

PSM3750 user manual

While it is not required for the user to define the selectivity, nominal values used by the PSM units are defined in the following table:

speed	update rate	normal time constant	slow time constant	Measurement Selectivity
fast	1/20s	0.2s	0.8s	24Hz
medium	1/3s	1.5s	6s	3Hz
slow	2.5s	12s	48s	0.4Hz
very slow	10s	48s	192s	0.1Hz

NOTE:

Some FRA instrument manufacturers use the term 'IF Bandwidth'. While this term is usually used in general electronics to refer to the intermediate frequency of analogue RF circuits, in FRA applications the term actually relates to measurement selectivity.

3 Using the menus

The PSM3750 is a very versatile instrument with many configurable parameters. These parameters are accessed from the front panel via a number of menus.

Each of the main menus may be accessed directly from a specific key.

ACQU	data acquisition parameters such as speed and filtering
SWEEP	frequency sweep control
TRIM	generator trim control (amplitude compression)
COMMS	communications options (RS232 etc)
ALARM	control of audible alarm and analogue output
OUT	signal generator control
CH1	channel 1 input control
CH2	channel 2 input control (and channel 3)
SYS	general system options such as phase convention, keyboard beep etc.
MODE	function control
PROG	recall/store/ delete of non-volatile programs

Each menu starts with the currently set parameters visible but no cursor. In this condition, pressing the menu key again or the HOME key aborts the menu operation and reverts back to normal operation.

To select any parameter, press the UP or DOWN key and a flashing box will move around the menu selecting each parameter. In this condition the keys take on their secondary function such as numbers 0-9, multipliers n-G etc.

Pressing the HOME key first time reverts to the opening state where the parameters are displayed but the cursor is

hidden. Pressing the HOME key at this point exits the menu sequence and reverts back to normal operation.

To abort the menu sequence, press the HOME key twice.

There are three types of data entry:

- selection from a list

- numeric

- text

3.1 Selection from a list

This data type is used where there are only specific options available such as the output may be 'on' or 'off', the graph drawing algorithm may use 'dots' or 'lines'.

When the flashing cursor is highlighting the parameter, the RIGHT key steps forward through the list, and the LEFT key steps backwards through the list. The number keys 0-9 step directly to that point in the list, which provides a quick way to jump through long lists. There is no need to press the ENTER key with this data type

For example, if the speed selection list comprises the options:

very slow	(item 0)
slow	(item 1)
medium	(item 2)
fast	(item 3)
window	(item 4)

and the presently selected option is "medium", there are 3 ways to select "window":

- press RIGHT twice
- press LEFT three times
- press number 4

3.2 Numeric data entry

Parameters such as frequency and offset are entered as real numbers; frequency is an example of an unsigned parameter, offset is an example of a signed parameter.

Real numbers are entered using the number keys, multiplier keys, decimal point key, or +/- key (if signed value is permitted). When the character string has been entered, pressing the ENTER key sets the parameter to the new value. Until the ENTER key is pressed, pressing the HOME key aborts the data entry and restores the original number.

If a data value is entered that is beyond the valid limits for that parameter then a warning is issued and the parameter set as close to the requested value as possible. For example, the maximum amplitude of the PSM3750 generator is 10V peak; if a value of 15V is entered, a warning will be given and the amplitude set to the maximum of 10V.

When the parameter is first selected there is no character cursor visible – in this condition, a new number may be entered directly and will overwrite the existing number.

To edit a data value rather than overwrite it, press the RIGHT key and a cursor will appear. New characters are inserted at the cursor position as the keys are pressed, or the character before the cursor position can be deleted with the DELETE key.

Data values are always shown in engineering notation to at least 5 digits (1.0000-999.99 and a multiplier).

3.3 Text entry

There are occasions where it is useful to enter a text string; for example, a non-volatile program may have some text as a title.

Text is entered by selecting one of 6 starting characters using the main function keys on the top right hand side of the keyboard (FRA etc), then stepping forwards or backwards through the alphabet with the UP and DOWN keys.

The starting letters are A (FRA), E (PAV), I (LCR), O (RMS), U (POWER), or space (SCOPE).

Numbers can also be inserted using the number keys.

The UP and DOWN keys step forward and backward using the ASCII character definitions – other printable characters such as # or ! can be obtained by stepping on from the space. The available character set is given in the Appendix.

When entering alphabetic characters, the ZOOM+ and ZOOM- keys select upper and lower case respectively for the character preceding the cursor and the next characters to be entered.

The editing keys, RIGHT, LEFT, DELETE and ENTER operate in the same way as for numeric entry.

4 Special functions

4.1 Display zoom

The PSM3750 normally displays many results on the screen in a combination of small font size (no zoom) and up to 4 values in a larger font size (first zoom level). There is also an even larger font for up to 4 selected values (second zoom level).

To set the data values for the larger font size, first return to no zoom by pressing ZOOM-, up to three times if necessary. Press ZOOM+ key to view the presently selected data, and press DELETE to clear the selection.

A flashing box surrounds the first available result. The flashing box is moved around the available results using the cursor keys, UP, DOWN, LEFT and RIGHT. Pressing the ENTER key selects the result for zoom and the box ceases to flash. Further results (up to four in total) can then be selected using the cursor keys in the same way – a solid box remains around the already selected item, and a new flashing box appears.

Having selected the desired results, pressing the ZOOM+ key invokes the first zoom level, pressing it again selects the higher level. Pressing ZOOM-, steps back down one level each time.

Note that any of the parameters selected for the zoom function can be used as the input for the alarm monitoring and analogue output.

4.2 Program store and recall

There are 999 non-volatile program locations where the settings for the entire instrument can be saved for recall at a later date. Each of the 999 locations has an associated name of up to 20 characters that can be entered by the user to aid identification.

Program number 1 (if not empty) is loaded when the instrument is powered on, so that the PSM3750 can be set to a user defined state whenever it is switched on. This is particularly useful to set system options such as phase convention etc. If no settings have been stored in program 1 then the factory default settings are loaded (program number 0).

Program numbers 1-6 may be recalled with a single press of the function keys if the direct load option is selected in the system menu (see system options).

The instrument can be restored to the factory default settings at any time by recalling program number 0.

The program menu is accessed using the PROG key. The program location can be selected either by stepping through the program locations in turn to see the name, or by entering the program number directly.

When storing a configuration in a program, there will be a slight pause (of about 1 second) if the program has previously been written or deleted. The process will be very quick if the location has not been used.

When supervisor mode is disabled (see system options), programs can only be recalled, not stored nor deleted, to avoid accidental modification.

4.3 Zero compensation

There are 3 levels of zero compensation:

- Trim out the dc offset in the input amplifier chain.
- Measure any remaining offset and compensate.
- Measure parasitic external values and compensate.

The trim of the dc offset in the input amplifier chain can be manually invoked at any time with the ZERO key, or over the RS232 with the REZERO command.

The measurement of the remaining offset also happens when the offset is trimmed but is also repeated at regular intervals when using a measurement function that requires dc accuracy (such as the rms voltmeter). This is to compensate for any thermal drift in the amplifier chain.

The compensation for parasitic external values (for example to compensate for the capacitance of the test leads when measuring capacitance) is invoked manually by the ZERO key. Refer to each function section for the function specific operations.

When the instrument settings are saved to a program file in the internal flash memory of the PSM3750, any single point or multiple point sweep compensation that has been undertaken will be included in that file. When the program file is recalled any compensation settings will also be recalled and will then be applicable. Each program memory location can include its own saved Single point or multiple point sweep compensation settings, these settings will be applied when that program is recalled including after the power cycling of the instrument.

To restore operation without function specific compensation press ZERO then select the clear option.

4.4 Alarm function

The PSM3750 has two independent alarms that can be read remotely or can generate an audible sound each of the alarms can be triggered by comparison to one or two thresholds:

- Sound the alarm if the value exceeds a threshold
- Sound the alarm if the value is below a threshold
- Sound the alarm if the value is outside a window
- Sound the alarm if the value is inside a window

Additionally, one of the alarms can be used to generate a sound which varies linearly between thresholds

The value to which each alarm is applied can be any of the measurements selected for zoom. The alarm status is also available as a logic output on the parallel port.

To program an alarm, first select the functions for the zoom; up to four measurements can be selected for the display, the alarm is applied to any of them; then press ALARM to invoke the alarm menu:

- Select which of the zoom functions is to be used
- Select the type of alarm
- Set the upper limit (if appropriate)
- Set the lower limit (if appropriate)
- Select whether the alarm is to be latched
- Select whether the alarm sounder is enabled

If the alarm latch is selected then the alarm will continue to sound even if the value returns to within the normal boundaries. To clear the alarm, press HOME.

The linear alarm option allows tests to be carried out even if it is not possible to see the display. Pressing ZERO in the alarm menu sets the upper and lower threshold to 4/3 and

PSM3750 user manual

1/3 of the measured value respectively. The repetition rate of the sounder then varies linearly as the value changes between these thresholds.

4.5 Analogue output

The analogue output is a 0 to 10V dc level that represents the selected measurement.

To program the analogue output, first select the functions for the zoom; up to four measurements can be selected for the display, the alarm is applied to any one of them; then press ALARM to invoke the alarm and analogue output menu:

- Select which of the zoom functions is to be used
- Set the value for zero volts output
- Set the analog scaling factor

The analog output level is computed as:

$$10 \times (\text{measured} - \text{zero}) / (\text{full scale} - \text{zero})$$

The output is updated whenever new data is available. For maximum update speed, select "fast analogue output" mode in the ACQU menu and enter a window value for 10ms or higher. When START is pressed, the instrument enters a special mode where all non-essential functions are suppressed (including the display). Press STOP to return to the normal display.

4.6 Data hold

When in real time display mode, the data on the display can be held at any time by pressing the REAL TIME key. When HOLD is activated a warning message is briefly displayed and the word HOLD appears in the top right hand corner of the display instead of the time.

Press the REAL TIME key again or the HOME key or START key to release HOLD; in this case, HOME and START do not have their normal functions.

When HOLD has been activated, the DSP continues to sample, compute and filter the results but the data is ignored by the CPU. When HOLD is released the display is updated with the next available value from the DSP.

4.7 Results store and recall

There are 999 non-volatile storage locations that can store either real-time results or frequency sweeps. Each location can store the sweep results for up to 50 points.

When storing a result, a text string may be entered to help identify the data.

Each stored result also saves the instrument configuration along with the data (same as program store/recall), so that the instrument is restored to the same settings when the result is recalled.

The results data may be restored manually or via communications for download to a PC. To manually access the results data store, press PROG and select memory type "results".

5 Using remote control

The PSM3750 is fitted with an RS232, USB serial, LAN and an IEEE488 (GPIB) interface. All the interfaces use the same ASCII protocol with the exception of the end of line terminators:

	Rx expects	Tx sends
RS232 USB	carriage return (line feed ignored)	carriage return and line feed
LAN	carriage return (line feed ignored)	carriage return and line feed
IEEE488	carriage return or line feed or EOI	carriage return with EOI

All the functions of the PSM3750 can be programmed via either interface, and results read back.

The commands are not case sensitive and white space characters are ignored (e.g. tabs and spaces). Replies from the PSM3750 are always upper case, delimited by commas, without spaces.

Only the first six characters of any command are important – any further characters will be ignored. For example, the command to set the generator frequency is FREQUE but the full word FREQUENCY may be sent as the redundant NCY at the end will be ignored.

Fields within a command are delimited by comma, multiple commands can be sent on one line delimited with a semi-colon eg.

AMPLIT, 1.5; OUTPUT, ON

Mandatory commands specified in the IEEE488.2 protocol have been implemented, (e.g. *IDN? *RST) and all commands that expect a reply are terminated with a question mark.

PSM3750 user manual

The PSM3750 maintains an error status byte consistent with the requirements of the IEEE488.2 protocol (called the standard event status register) that can be read by the mandatory command *ESR? (See section 5.1).

The PSM3750 also maintains a status byte consistent with the requirements of the IEEE488.2 protocol, that can be read either with the IEEE488 serial poll function or by the mandatory command *STB? Over RS232 or IEEE or LAN (see section 5.2).

The IEEE address defaults to 23 and can be changed via the COMMS menu. Setting the LAN IP address to 0.0.0.0 will enable the DHCP and the unit will obtain its IP-Address from the DHCP server. DHCP server must be present on the network for this to work. The LAN will not start normal operation until it receives an IP address from the server.

Setting the LAN IP manually will disable the DHCP and the unit will use a fixed IP address, defined by the IP Address setting in the REMOTE menu.

The keyboard is disabled when the instrument is set to "remote" using the IEEE. Press HOME to return to "local".

RS232 data format is: start bit, 8 data bits (no parity), 1 stop bit. Flow control is RTS/CTS (see section 5.2), baud rate is selectable via the COMMS menu. When connecting to a PC use the supplied null modem cable.

A summary of the available commands is given in the Appendix. Details of each command are given in the communication command manual.

Commands are executed in sequence except for two special characters that are immediately obeyed:

PSM3750 user manual

Control T (20) – reset interface (device clear)

Control U (21) – warm restart

To maintain compatibility with some communication systems, there is an optional “protocol 2” which requires a space between the command and any arguments.

5.1 Standard event status register

PON		CME	EXE	DDE	QYE		OPC
-----	--	-----	-----	-----	-----	--	-----

- bit 0 OPC (operation complete)
cleared by most commands
set when data available or sweep complete
- bit 2 QYE (unterminated query error)
set if no message ready when data read
- bit 3 DDE (device dependent error)
set when the instrument has an error
- bit 4 EXE (execution error)
set when the command cannot be executed
- bit 5 CME (command interpretation error)
set when a command has not been recognised
- bit 7 PON (power on event)
set when power first applied or unit has reset

The bits in the standard event status register except for OPC are set by the relevant event and cleared by specific command (*ESR? *CLS, *RST). OPC is also cleared by most commands that change any part of the configuration of the instrument (such as MODE or START).

5.2 Serial Poll status byte

		ESB	MAV		FDV	SDV	RDV
--	--	-----	-----	--	-----	-----	-----

- bit 0 RDV (result data available)
set when results are available to be read as enabled by DAVER
- bit 1 SDV (sweep data available)
set when sweep results are available to be read as enabled by DAVER
- bit 2 FDV (fast data available (streaming))
set when data streaming results are available to be read as enabled by DAVER
- bit 4 MAV (message available)
set when a message reply is waiting to be read
- bit 5 ESB (standard event summary bit)
set if any bit in the standard event status register is set as well as the corresponding bit in the standard event status enable register (set by *ESE).

5.3 RS232 connections

The RS232 port on the PSM3750 uses the same pinout as a standard 9 pin serial port on a PC or laptop (9-pin male 'D' type).

Pin	Function	Direction
1	DCD	in (+ weak pull up)
2	RX data	in
3	TX data	out
4	DTR	out
5	GND	
6	DSR	not used
7	RTS	out
8	CTS	in
9	RI	not used

The PSM3750 will only transmit when CTS (pin 8) is asserted, and can only receive if DCD (pin 1) is asserted. The PSM3750 constantly asserts (+12V) DTR (pin 4) so this pin can be connected to any unwanted modem control inputs to force operation without handshaking. The PSM3750 has a weak pull up on pin 1 as many null modem cables leave it open circuit. In electrically noisy environments, this pin should be driven or connected to pin 4.

To connect the PSM3750 to a PC, use a 9 pin female to 9 pin female null modem cable:

1 & 6	-	4
2	-	3
3	-	2
4	-	1 & 6
5	-	5
7	-	8
8	-	7

6 System options

Press SYSTEM to access the system options.

The time and date are maintained by a battery backed real time clock. Time is expressed in 24 hour format.

The display is normally in colour but it can be set to black on white or white on black.

There is a choice of screen brightness – “high” suits most typical environments but “low” may cause less eye strain in low light conditions.

Measurements of phase can be expressed in one of three conventional formats:

- 180° to +180° (commonly used in circuit analysis)

- 0° to -360° (commonly used in power applications)

- 0° to +360°

The measurement is exactly the same it is only the way that it is expressed that changes.

Blanking can be applied to a number of measurements so that zero is shown when the measurement is below a certain level. This blanking can be disabled if desired.

Each key press is normally accompanied by an audible ‘beep’ as well as the tactile ‘click’. The ‘beep’ can be disabled for quiet environments if the feel of the key is sufficient feedback

When High Voltage Protection mode is enabled the autozero function is disabled if any of the channels show a measurement of 100V or above. When this mode is enabled a message is automatically displayed when the instrument is switched on. The message will be displayed until the user presses the HOME key.

PSM3750 user manual

The message can be prevented from being displayed when the instrument is powered on. To disable the message, "Begin measurements on Power Up" should be set to ON. Whilst this prevents the message from being displayed it does NOT disable High Voltage Protection Mode.

The 6 main function keys, FRA, PAV, LCR, RMS, POWER, HARM, can be used to load stored configurations as a "one-touch" way of configuring the instrument for specific applications. This is particularly useful in a production environment where an operator has a small number of specific tests to perform.

Most data is displayed to 5 digits but for extra resolution 6 digits can be displayed when in ZOOM level 2 or 3.

When using external shunts or attenuators, the range can be shown either as the normal peak voltage or scaled by the shunt or attenuator factor.

Levels are usually expressed in volts but can be set and displayed in dBm, which is a logarithmic scale referred to 1mW in 600 Ω , often used when testing communications components.

To save these system settings as default, store the setup in program 1 so that they are reloaded on power on.

Pressing RIGHT from the SYSTEM OPTIONS menu selects the USER DATA screen (see next section).

Pressing LEFT from first SYSTEM OPTIONS menu displays the serial number, release versions, and calibration date.

6.1 User data

The PSM3750 can be personalised by entering up to 3 lines of user data as text (see section on text entry).

User data is displayed every time that the instrument is switched on to identify the instrument. The entered text may also be read over the communications to identify the instrument (see USER?).

Typical arrangement of the user data might be:

- line 1 company name
- line 2 department or individual name
- line 3 unique identifying number (eg. asset number)

Any user data may be entered as required, as the lines are treated purely as text and are not interpreted by the PSM3750 at all.

For use in a production environment, the PSM3750 supports two modes of operation, supervisor and user. When supervisor mode is disabled, the stored programs can only be recalled, not changed. In user mode the PSM3750 will also not accept any commands which could change the calibration data.

After changing the user data or supervisor status, execute 'store' to save the data in non-volatile memory.

7 Measurement options

7.1 ACQU - Acquisition options

The PSM3750 comes in 2 channel or 3 channel version. The 3 channel version can be set to display just 2 channels if the third channel is not in use.

In normal acquisition mode the window over which the measurements are computed is adjusted to give an integral number of cycles of the input waveform. The results from each window are passed through a digital filter equivalent to a first order RC low pass filter.

There are six pre-set speed options – very fast, fast, medium, slow, very slow and window – that adjust the nominal size of the window, and therefore the update rate and the time constant of the filter. Greater stability is obtained at the slower speed at the expense of a slower update rate.

Note that the measurements have to be made over an integral number of cycles of the waveform so the window is extended to cover one or more complete cycles even if this is a longer period than the nominal update rate. The minimum number of cycles to be measured in each window can be set from 1 to 100.

There are two time constants for the filter, normal or slow, or the filter can be deselected. The filter applies an auto reset function to give a fast dynamic response to a change of measurement – this function can be deselected and the filter forced to operate with a fixed time constant for use with noisy signals.

PSM3750 user manual

The nominal values are:

speed	update rate	normal time constant	slow time constant
very fast	1/50s	0.1s	0.4s
fast	1/12s	0.4s	1.5s
medium	1/3s	1.5s	6s
slow	2.5s	12s	48s
very slow	10s	48s	192s

There is also an option to set a specific size of the window to a value other than the preset options. In order to synchronise to an integral number of cycles, the window size is either reduced by up to 25% or increased as necessary.

The filter dynamics are usually set to "auto reset" where the filtering is reset in response to a significant change in data. This speeds up the response of the instrument to changing conditions. This function can be disabled so that the filtering has a fixed time constant, which would have an exponential response to a step change. The filter can also be reset by pressing TRIGGER.

When the generator is not used and so the measurement is synchronised to the input frequency measured on CH1, there is a low frequency option that extends the frequency measurement down to 20mHz. This low frequency option also applies a digital filter, which can be useful when measuring in a low frequency, noisy environment.

In the case where there is very little signal on CH1, the reference for the phase can be set to another channel to give a more accurate measurement. This does not change the phase result it only helps to reduce the uncertainty due to noise.

The bandwidth of the instrument, usually set to "auto", can be forced to "wide" or "low". When not in auto selection, heterodyning is disabled and the bandwidth is either 5MHz (wide) or 100 KHz (low) to minimise noise when making measurements at low frequencies.

7.1.1 Advanced options

Pressing ACQU to access the acquisition control menu then the right arrow key gives access to some advanced options which would not be needed for normal measurement applications.

The analysis for the fundamental component uses a DFT (discrete Fourier transform) algorithm. The selectivity of the DFT analysis is a compromise between noise rejection of frequencies close to the frequency of the fundamental component and the required stability of the frequency component. Selecting "narrow" increases the selectivity of the DFT analysis (reducing the effective bandwidth) which has the effect of improving the noise rejection. It does, however, require that the frequency of the fundamental component is more stable.

In a noisy application, any spikes present on the signal may push the instrument onto a higher range than is necessary for the signal being measured. If the nature of the spurious spikes are such that they do not contribute to the measurement and can safely be ignored then the range can be manually set to the appropriate range for the signal to be measured and the instrument can be told to ignore any overload.

When "frequency lock - Constant" is selected the present measured frequency is displayed but this can be overwritten with the known frequency. This entered frequency is then used for all the analysis and the frequency of the input signal is not measured.

7.2 Datalog

The PSM3750 can store and display measurements recorded at regular intervals over a time period. Each data record consists of the elapsed time and up to four data values selected by ZOOM.

The actual interval between data points is governed by the measurement speed and the datalog interval. The PSM3750 stores the next available measurement after the datalog interval has elapsed: the actual elapsed time is attached to each datalog record, is displayed with the data on the table or each graph, and returned with each record over the communications (RS232, USB, LAN or GPIB).

The data values may be stored to RAM or directly into either internal non-volatile memory or USB memory stick as each value becomes available. (Note that 2GB is the maximum allowable size of USB memory stick that can be used). The non-volatile option is useful for acquiring data over long periods, to prevent the loss of data in the event of a power failure.

The RAM datalog can hold up to 32000 records if one value is selected; more than 12000 records if four values are selected. Data that has been stored into RAM may be subsequently transferred to non-volatile memory using the PROG menu.

For high speed data acquisition, the datalog interval may be set to zero so that each measurement is stored. The measurement interval is controlled with the "speed" option in the ACQU menu. Using the "window" option for speed, allows greater control of the measurement interval. In this mode, the display flashes "DATALOG RUNNING" and only shows the acquisition time. The minimum datalog interval depends on the function but is typically 10ms.

PSM3750 user manual

Note that in all cases the measurement interval is necessarily adjusted to be an integral number of cycles of the measured waveform.

The datalog options are set up with the ACQU menu. The datalog is started with the START key, and stopped with the STOP key unless the store becomes full first. The zero reference for the elapsed time is taken as the first data measurement after START.

The data can be viewed as a table or as individual graphs. Pressing GRAPH steps the graph through the stored parameters. If more than 250 records have been stored, the graph can show the data for the whole period or pressing ZOOM redraws the graph to show 250 records about the cursor. The cursor can be moved in single steps (LEFT or RIGHT) or large steps (UP or DOWN). Pressing UNZOOM shows the whole data gain. Movements of the cursor are synchronised in both the TABLE and GRAPH views.

7.3 SWEEP - Frequency sweep options

All ac measurements using the PSM3750 generator can be swept across a frequency range. The start frequency, stop frequency and number of steps up to 2000 can be specified. The measurements are subjected to the same speed constraints set in the ACQU menu, but the filtering does not apply on each measurement point. If continuous sweep is selected, then the filtering is applied to each successive sweep.

The graph normally sets the y axis automatically to the extremes of the measurements (or in FRA mode to 20dB/decade of frequency) but the axis can be fixed if required. The graph of the second parameter (usually phase) can also be independently manually set.

A vertical marker can be placed on the graph to reference a specific frequency.

Each frequency point is an entirely new measurement and autoranging is restarted (if enabled). For the fastest possible sweeps, select manual ranging. As each frequency point is a new measurement, filtering has no effect on a single sweep, but fixed time filtering can be applied independently on each frequency point if repeat sweep is selected.

For maximum sweep speed, particularly when using a large number of points, there is a "fast sweep" mode which disables all non-essential functions, including the display, during the sweep. In this mode the display is blank except for a flashing message "ACQUIRING SWEEP DATA" until the full sweep has been completed when normal display functions are restored. This mode is automatically selected when a user defined window of less than 100ms has been set.

7.4 TRIM - Trim function

The trim function on the PSM3750 is a powerful and versatile feature that allows closed loop control of the generator amplitude. It allows a specific measurement from CH1, CH2 or CH3, if fitted, and the generator output will be adjusted to maintain the measured voltage or current. This allows the excitation level to be controlled over changing conditions such as a frequency sweep.

At each measurement point, the measured level is checked against the specified level and tolerance; if an adjustment is needed the data is discarded and a new measurement made at the new output level. The user is alerted to the adjustment by an audible beep.

Particularly important in control loop analysis, where it is sometimes referred to as amplitude compression, it prevents the control loop being overdriven as the frequency changes.

It is also useful in a more general case where test levels are specified.

Note that when dBm mode level control is selected, the trim level is entered as dBm but the tolerance remains a linear percentage of the actual voltage not the logarithmic dBm measure.

8 Output control

The output for the signal generator is digitally synthesised at an update rate of 150Msamples/s. With the output filtering, this gives a good sinewave waveform, even at 35MHz, while preserving very accurate frequency control.

The output amplitude is controlled in 2 stages – a fine control with 10 bit resolution, with coarse control with 5 steps. This gives 10mV resolution at high output levels and 1mV resolution at low output levels.

The maximum output available from the generator is a function of frequency:

max frequency MHz	output level into 50Ω	
	peak V	rms V
1	7.5	5
5	5	3.5
10	3	2
15	2	1.4
20	1.5	1
25	1.2	0.8
30	1	0.7
35	0.75	0.5
40	0.6	0.5
50	0.4	0.25

An offset may be added to any output to bias the signal or to null out any dc present with a resolution of +/-10mV.

The LEFT and RIGHT keys adjust the frequency of the generator by a fixed increment stored via the STEP menu; the UP and DOWN keys adjust the amplitude (except for

the harmonic analyser and power analyser where UP and DOWN step the selected harmonic).

The generator output may be set to be on, off, or dc only.

When the generator is switched off the RAMP function can be selected so that the output gradually ramps down to zero. When RAMP OFF is set to off (default) the output will drop to zero instantly when the output is switched off.

Advanced Options:

Generator Adjust: The voltage output generator uses a combination of linear gain and db gain in hardware, the output range is separated into three voltage bands. Each band of voltages has different settings for the linear and db gain. When using the generator adjust option, the adjustment is only valid for the band in which the adjustment was performed. These bands are detailed below;

- a) 2.5 to 14.1V
- b) 0.5 to 2.5V
- c) < 0.5V

8.1 Generator specifications

General	
accuracy	frequency $\pm 0.05\%$
accuracy (with trim)	amplitude $\pm 5\% < 10\text{MHz}$, $\pm 10\% < 50\text{MHz}$
output impedance	$50\Omega \pm 2\%$
output voltage	$\pm 15\text{V}$ peak (Open Circuit) *
Offset	$\pm 10\text{V}$ peak maximum
waveforms	sine, square, triangle, sawtooth, pulse and white noise
frequency	10uHz to 50MHz
output control	10mV to 2mV steps
Type	direct digital synthesis
update rate	210MHz
DAC resolution	14 bit
phase accumulator	48 bit

*The absolute amplitude of the generator signal is unimportant in FRA mode, it is only the relative magnitude between two measured inputs that is required, and the absolute amplitude is largely irrelevant in LCR mode, as it is only the relative magnitude/phase angle of two inputs that is required.

In the few applications in which generator accuracy becomes important, then the ability to use the TRIM function (See section 7.4) provides that ability.

9 Input channels

The two or three input channels are fully isolated from each other and earth. The two channels are controlled independently but sampled synchronously.

Each input channel may be selected to be:

- direct
- external shunt
- external attenuator

If the external shunt option is selected, the data is scaled by the shunt value (entered under the relevant channel menu) and the units are displayed in Amps. Any resistor can be used as a shunt, or precision low inductance current shunts are available as accessories. Current transformers can be used if fitted with an appropriate burden resistor.

Note that the external shunt input polarity is reversed compared to that of the voltage input: ie the - input becomes non-inverting and the + input becomes inverting. This is so that the capacitance to ground of the probe cable screen is driven with the lower source impedance in order to minimise errors at high frequency.

Note that some modes force the input channels to be voltage or current automatically, eg. the power meter defaults to channel 1 as voltage and channel 2 as current. This automatic selection can be overridden if required.

The input ranges have nominal full scale values set with a ratio of $1:\sqrt{10}$ from 3mV to 300V and a top range of 500V. This gives the following ranges:

PSM3750 user manual

range	reference	nominal full scale
1	3mV	3.16mV
2	10mV	10mV
3	30mV	31.6mV
4	100mV	100mV
5	300mV	316mV
6	1V	1V
7	3V	3.16V
8	10V	10V
9	30V	31.6V
10	100V	100V
11	300V	316V
12	500V	1000V

Because of slew rate limitations of the input amplifiers, the maximum input signal that can be accurately measured varies with frequency:

frequency MHz	max input level	
	peak V	rms V
4	500	353.5
5	400	282.8
10	200	141.4
20	100	70.7
25	80	56.5
40	50	35.3
50	40	28.3

The input ranges may be selected manually, or by autoranging (default). The start range for autoranging may be selected if it is known that the signal will not be below a certain level.

There is also an option to autorange 'up only' so that a test may be carried out to find the highest range. Once the highest range has been determined, the range can be set to manual and the measurement made without losing any data due to range changing. Pressing the HOME key (or sending *TRG) restarts the autoranging from the selected minimum range.

When in an input channel menu, the ZERO key provides a quick way to lock and unlock the range. When no flashing box is visible in the input channel menu and autoranging is selected, pressing the ZERO key selects the range that the instrument is currently using and sets the autoranging to manual, thus locking the range and preventing further autoranging. Pressing the ZERO key again returns to full autoranging from the bottom range.

For most measurement functions full autoranging is the most suitable option but some applications, such as where transient events are occurring, are more reliable with manual ranging. Manual ranging (or up-only autoranging) is essential for low frequency measurements.

For measuring signals that are biased on a dc level (such as an amplifier operating on a single supply or the output of a dc PSU), ac coupling can be used. AC+DC coupling is the normal option and should be used where possible. **Note** AC only coupling should not be used below 20Hz as the results are not meaningful.

A scaling factor can be entered for each channel for use with attenuators such as x10 oscilloscope probes. A nominal value can be entered or the attenuation factor of the probe can be measured and the precise value entered. The measured voltage will be displayed after multiplication by the scale factor. The scale factor can be set automatically by pressing TRIG when in an input channel menu. For example, with a x10 oscilloscope probe on

channel 1 input, a x1 probe on channel 2 input and both probes connected to the same voltage; press CH1 to invoke the input menu for channel 1 then press TRIG and the scale factor for channel 1 is computed so that channel 1 reads the same as channel 2. Note that when using external divider probes to increase the maximum input voltage it is important to use active probes if accurately measuring dc. This because the dc input impedance is different from the ac input impedance. When using passive probes the dc would read about 10% high.

If the channel has been set for use with an external shunt then the value of the shunt can be entered.

The secondary channel has a control to adjust the gain so that common mode rejection may be maximised when using oscilloscope probes.

9.1 Trimming x10 oscilloscope probes

To minimise the loading effects at high frequencies, x10 oscilloscope probes can be used with the PSM3750. For optimum performance, the probes need to be trimmed to match the input capacitance of the instrument and the probes need to be corrected for gain errors. A small plastic screwdriver is provided with each probe for this purpose. In all, there are three processes that must be carried out to optimise the performance:

- probe trim
- probe scaling

Connect the instrument output across a convenient resistor (anything above 1k) using the supplied BNC to crocodile clip output lead. Connect the probes from the input channels across the resistor. Observe the colour of which probe connects to each of the four input terminals for future use.

Press OUT and set the generator to 1kHz squarewave with 2V amplitude. Press HARM to invoke harmonic analyser mode and select third harmonic. Set all probes to x1.

To trim the probes connected to the main inputs.

The measured third harmonic should read 33.33% +/- 0.05%. Select x10 on one of the probes and adjust the trimmer in the body of the probe until the third harmonic again reads the same value. Switch the probe back to x1 and verify that the third harmonic reads the same. Repeat the adjustment if necessary. Select x10 on the other probe and adjust in the same way. To verify the adjustment at higher frequency, select the 25th harmonic for measurement. The reading should be 4.00% +/- 0.5% in both x1 and x10 settings.

To adjust for the tolerance within the probes (typically 1%), the main inputs can be scaled and the secondary inputs can be adjusted. Press OUT and set 1kHz sinewave, 2V amplitude; and press FRA to invoke frequency response analyser.

To adjust for tolerance within the probes connected to the main inputs:

With both probes set to x1 check that the measured magnitudes are about the same. Set the probe connected to CH1 to x10 and set the probe connected to CH2 to x1. Press CH1 then TRIG – the scaling factor for channel 1 will be automatically adjusted to a number about 10. Press HOME to exit the menu and observe that the readings for CH1 and CH2 are again about the same.

Set the probe connected to CH1 to x1 and set the probe connected to CH2 to x10. Press CH2 then TRIG – the scaling factor for channel 2 will be automatically adjusted to a number about 10. Press HOME to exit the menu and observe that the readings for CH1 and CH2 are again about the same.

If you have a three channel instrument set the probe connected to CH1 to x1 and set the probe connected to CH2 to x10. Press CH2 then RIGHT to access the CH3 menu. Press TRIG and the scaling factor for channel 3 will be automatically adjusted to a number about 10. Press HOME to exit the menu and observe that the readings for CH1 and CH3 are again about the same.

10 True RMS Voltmeter

The RMS voltmeter measures the total rms of the signal present at the input terminals to the bandwidth of the instrument (>1MHz). Care must be taken when measuring low signal levels to minimise noise pick on the input leads.

The RMS voltmeter measures the elementary values:

rms
dc
peak
surge
mean

And derives the values: ac, dBm, crest factor and form factor.

The rms value of a periodic waveform, $v(\phi)$, is given by:

$$\text{rms} = \sqrt{\left[\frac{1}{2\pi} \int_0^{2\pi} v^2(\phi) d\phi \right]}$$

For a sampled signal, the formula becomes:

$$\text{rms} = \sqrt{\left[\frac{1}{n} \sum_{i=0}^{i=n-1} v^2[i] \right]}$$

Where n is the number of samples for an integral number of complete cycles of the input waveform.

These are fundamental definitions that are valid for all waveshapes. For a pure sinewave, the formulae equate to $\text{peak}/\sqrt{2}$, but this cannot be applied to other waveshapes. The PSM3750 computes the true rms value from the fundamental definition for sampled data.

The dc present is given by:

$$dc = 1/2\pi \int_0^{2\pi} v(\phi) d\phi$$

For a sampled signal, the formula becomes:

$$dc = 1/n \sum_{i=0}^{i=n-1} v[i]$$

Where n is the number of samples for an integral number of complete cycles of the input waveform.

Having computed the true rms and the dc component, the ac component can be derived from:

$$rms^2 = ac^2 + dc^2 \quad \Rightarrow \quad ac^2 = rms^2 - dc^2$$

The ac component is also expressed in dB referred to 1mW into 600Ω (dBm):

$$dBm = 20 \log (V_{ac}/V_{ref})$$

where $V_{ref} = \sqrt{(1mW \times 600\Omega)}$

or $20 \log (I_{ac}/I_{ref})$

where $I_{ref} = \sqrt{(1mW / 600\Omega)}$

The peak measurement is simply the value with the largest magnitude. Positive and negative peaks are independently filtered then the result with the largest magnitude is taken as the peak value.

PSM3750 user manual

In order to measure surge conditions, the maximum instantaneous peak value (unfiltered) is also recorded. It is important that the PSM3750 does not autorange while measuring surge – either set the range to manual or repeat the test with ranging set to up only. To reset the maximum, press START.

Crest factor is derived from the peak and rms:

$$cf = \text{peak} / \text{rms}$$

The rectified mean measurement is given by:

$$\text{mean} = 1/2\pi \int_0^{2\pi} |v(\phi)| d\phi$$

For a sampled signal, the formula becomes:

$$\text{mean} = 1/n \sum_{i=0}^{i=n-1} |v[i]|$$

The mean is then normalised to give the same value as rms for a pure sinewave:

$$\text{Normalised mean} = \text{mean} \times \pi/2\sqrt{2}$$

Form factor is derived from the normalised mean and rms:

$$ff = \text{mean} / \text{rms}$$

The measurements are computed over rectangular windows with no gaps. The processing power of the DSP allows the measurements to be made in real time without missing any samples. In this way, the measured rms is a true value even if the signal is fluctuating. The only

PSM3750 user manual

occasion when data is missed is when an autozero measurement is requested.

The ZOOM function can be used to select any combination of up to four parameters from the display.

Note that the wideband nature of true rms measurements prevents the use of heterodyning so the frequency range of the measurement is limited to 5MHz. To minimise noise, there is a 100kHz filter applied by default. To obtain the full bandwidth press ACQU, highlight bandwidth and select "wide".

10.1 RMS voltmeter specification

DVM	
Channels	2 or 3 fully isolated
Display	5 digits
measurement	true rms, ac, dc, dBm, peak, cf, surge.
Coupling	ac or ac+dc
frequency	DC to 5MHz (heterodyning not available) AC+DC 20Hz to 5MHz
max input	±500V peak
input ranges	*300mV, *1V, *3V, *10V, *= High Voltage Attenuator. 500V, 300V, 100V, 30V, 10V, 3V, 1V, 300mV, 100mV, 30mV, 10mV, 3mV
Ranging	full auto, up only, or manual
input impedance	1M // 30pF (exc. leads)
accuracy (ac)	0.075% range + 0.075% reading + 0.1mV <1kHz above + 0.003%/kHz < 5MHz
accuracy (dc)	0.1% range + 0.1% reading + 0.5mV
CMRR (typical)	160dB @ 230V 50Hz 140dB @ 100V 1kHz 70dB @ 10V 1MHz
time constant	0.2s, 1.5s or 12s

Conditions:

- 23°C +/- 5°C ambient temperature
- instrument allowed to warm up for ≥30 minutes
- Sinewave
- slow speed, normal filtering
- ac+dc coupling
- autoranging or manual ranging ≥ 1/3 range

11 Frequency response analyser

The PSM3750 measures the gain and phase of channel 2 relative to channel 1 using a discrete Fourier transform (DFT) algorithm at the fundamental frequency.

The DFT technique can measure phase as well as magnitude and is inherently good at rejecting noise – it is much more reliable than measuring the rms at one point relative to another point.

The circuit can be characterised by computing the gain and phase at a number of points over a frequency range. This gives results that show the transfer function of the circuit as a graph on the display.

The DFT analysis yields two components – in-phase and quadrature, or 'a' and 'b' values – from which the magnitude and phase can be derived.

Considering the components at the fundamental frequency:

The fundamental in-phase and quadrature values of a periodic waveform, $v(\phi)$, are given by:

$$a_1 = \frac{1}{\pi} \int_0^{2\pi} v(\phi) \cdot \cos(\phi) \, d\phi$$

$$b_1 = \frac{1}{\pi} \int_0^{2\pi} v(\phi) \cdot \sin(\phi) \, d\phi$$

For a sampled signal, the formulae become:

$$a_1 = 1/n \sum_{i=0}^{i=n-1} v[i].\cos(2\pi ci/n)$$

$$b_1 = 1/n \sum_{i=0}^{i=n-1} v[i].\sin(2\pi ci/n)$$

Where n is the number of samples for an integral number of complete cycles of the input waveform, and c are the number of cycles.

Having computed the real and quadrature components, the magnitude and phase of each channel can be derived:

$$\text{mag} = \sqrt{a_1^2 + b_1^2}$$

$$\theta = \tan^{-1}(b_1/a_1)$$

The relative gain and phase of the circuitry under test at that particular frequency is derived from the real and quadrature components by vector division:

$$\text{vector gain} = (a + jb) \{\text{ch2}\} / (a + jb) \{\text{ch1}\}$$

$$\text{gain} = \text{magnitude}(\text{vector gain})$$

$$\text{phase} = \tan^{-1}(b/a(\text{vector gain}))$$

The gain is usually quoted in dB:

$$\text{dB} = 20 \log_{10}(\text{gain})$$

PSM3750 user manual

To look at differences in gain from a nominal value, an offset gain can be applied either manually or by pressing ZERO.

$$\text{Offset gain} = \text{measured dB} - \text{offset dB}$$

The filtering is applied to the real and quadrature components individually, rather than the derived magnitude and phase values. This gives superior results as any noise contribution to the components would have random phase and therefore would be reduced by filtering.

The PSM3750 can operate either in real time mode at a single frequency where the gain and phase are filtered and updated on the display; or it can sweep a range of frequencies and present the results as a table or graphs of gain and phase.

The frequency points to be measured are specified with three parameters:

- number of steps
- start frequency
- end frequency

The PS3750 computes a multiplying factor that it applies to the start frequency for the specified number of steps. Note that due to compound multiplication it is unlikely that the end frequency will be exactly that programmed. The frequency sweep is initiated by the START key, and when completed the data can be viewed as a table or graphs.

Following a sweep on a control loop, the gain and phase margins can be computed and displayed on the graph.

The window over which the measurements are computed is adjusted to give an integral number of cycles of the input waveform. In real time mode the results from each window are passed through a digital filter equivalent to a first order RC low pass filter; in sweep mode each result

comprises a single window without any filtering unless repeat sweep is selected.

The top of the vertical axis for the graph is normally set to be the highest measured value during the sweep. The bottom of the vertical axis is normally either set to the lowest measured value or the result of the highest value less 20dB/decade of frequency. The vertical axis can be fixed to a manual scale using the menus.

The ZOOM function can be used to select up to four parameters from the display when in real time mode. It has no function following a sweep.

Following a sweep the GRAPH key selects between:

- Graph of gain v frequency

- Graph of phase v frequency

- Graph of gain and phase v frequency

If three channels are being used then the three graphs above are repeated for computation 2 (as selected in the main FRA menu).

Pressing HOME or TRIG restarts the real time measurement at the selected frequency.

Although it is most usual to use the PSM3750 generator when performing gain/phase analysis, there may be circumstances where this is impractical, for example measuring across a transformer under load. In this case, turn off the PSM3750 generator (OUT menu) and the frequency reference for the analysis is measured from channel 1. Provided that the signal is clean enough for an accurate frequency measurement (and for DFT analysis the frequency does need to be accurately known), then the gain and phase can be measured reliably.

When using an external frequency reference there can be no sweep function.

11.2 Quick start guide to Feedback Loop Analysis

This section is aimed as a helpful guide to enable you to set up your PSM3750 with the aid of screenshots and instructions with respect to Feedback Loop Analysis.

Setting Input Channels to be used.

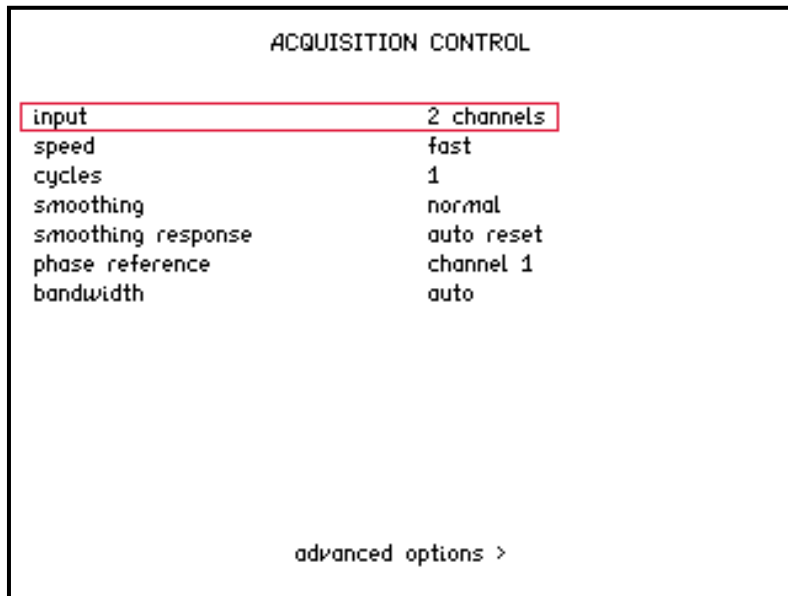

Action

Result

Press 'ACQU'	Acquisition Control Menu appears
Press '↓'	Flashing Red Box appears around the Input Channels selection
Press '→'	Flashing Red Box appears around 2 channels / 3 channels
Press '↓'	Select 2 Channel Option
Press 'ENTER'	2 Channels have been selected as the Input
Press 'HOME'	Flashing Red Box now disappears
Press 'HOME'	Display returns to measurement window

*Depending on the actual measurements to be made it may also be necessary to Use the '↓' key to step down the screen until the Flashing Red Box appears around the Speed Setting. Then select the desired speed from the drop down list. Press 'ENTER' then 'HOME' twice to return to the measurement window.

Setting the Amplitude and Output to On.

OUTPUT	
waveform	sinewave
amplitude control	V
amplitude	300.00mVpk
amplitude step size	1.1000 times
offset	+0.0000 V
frequency	16.000k Hz
step type	logarithmic
frequency step size	2.0000 times
phase control	off
output	on

Action

Result

Press `OUT`	Output Control Menu appears
Press `↓` 3 TIMES	Flashing Red Box appears around the Amplitude Setting
Press `300m`	300mv now appears in the Amplitude Option
Press `ENTER`	300mv is selected as the Amplitude
Press `↓` 7 TIMES	Flashing Red Box appears around the Output Mode
Press `→`	Off, On, DC Only, options appear on screen
Press `↓`	Select `On` option
Press `ENTER`	Output On is now selected
Press `HOME`	Flashing Red Box will now disappear
Press `HOME`	Display returns to measurement window

*Depending on the actual measurements to be made it may also be necessary to Use the `↓` key to step down the screen until the Flashing Red Box appears around the Frequency Setting. Then type in the desired frequency. Press `ENTER` then `HOME` twice to return to the measurement window.

PSM3750 user manual

Gain and Phase Margins: Enable / Disable

MEASUREMENT SETTINGS	
mode	frequency response analyzer
speed	fast
smoothing	normal
smoothing response	auto reset
computation 1	ch2/ch1
offset	0.0000 dB
gain/phase margins	enabled
graph	phase

Action

Result

Press 'MODE'	Measurement Settings Control Menu appears
Press '↓' 7 TIMES	Flashing Red Box appears around the Gain / Phase selection
Press '→'	Flashing Red Box appears around disabled / enabled options
Press '↓'	Select Enabled Option
Press 'ENTER'	Enabled Option has now been selected for the Gain / Phase margins
Press 'HOME'	Flashing Red Box now disappears
Press 'HOME'	Display returns to measurement window

*Depending on the actual measurements to be made it may also be necessary to Use the '↓' key to step down the screen until the Flashing Red Box appears around the Speed Setting. Then select the desired speed from the drop down list. Press 'ENTER' then 'HOME' twice to return to the measurement window.

Setting Channels 1&2 Input Ranges & Coupling

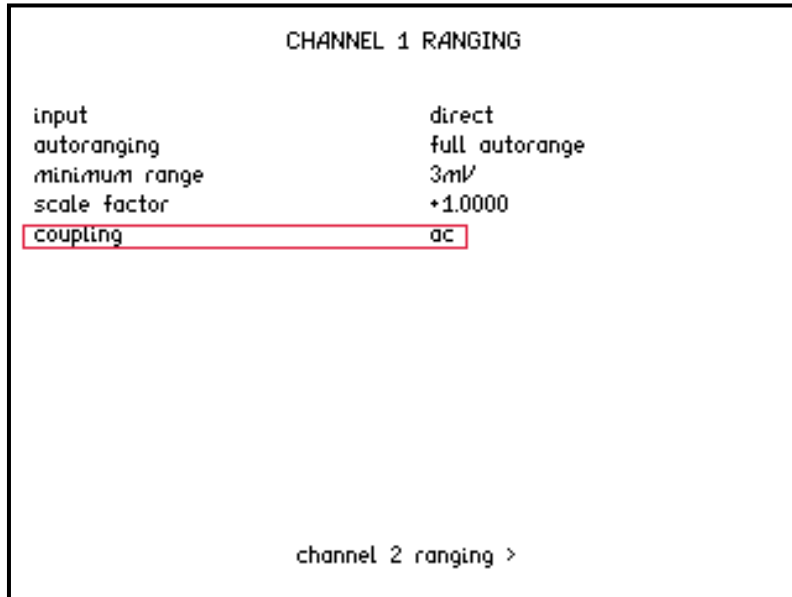

Action

Press `CH 1`

Press `↓` 5 TIMES

Press `→`

Press `↓`

Press `ENTER`

Press `HOME`

Press `HOME`

Result

Channel 1 Control Menu appears

Flashing Red Box appears around the Coupling selection

Flashing Red Box appears around ac+dc, ac options

Select ac only

Flashing Red Box appears around ac selection

Flashing Red Box now disappears and ac is selected

Display returns to measurement window

To change any of the other Input settings follow steps as above to enable the parameters to be amended

PSM3750 user manual

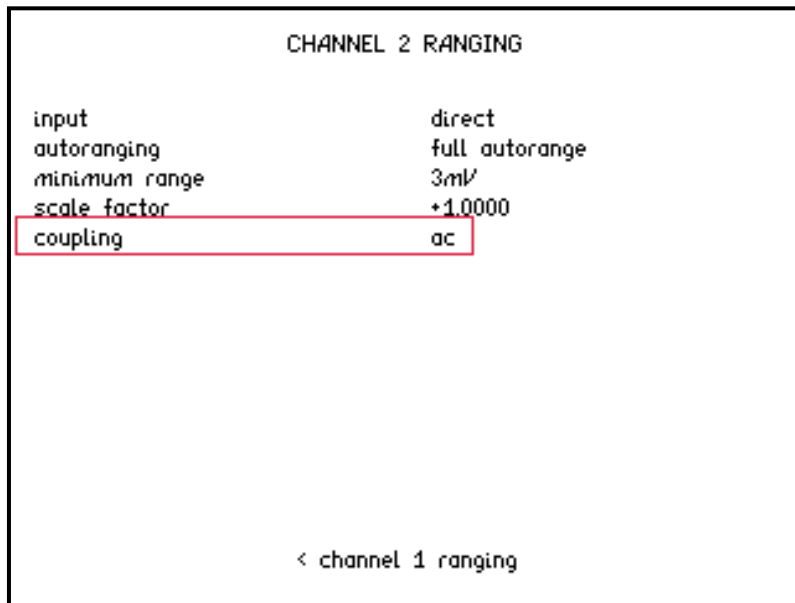

Action

Result

Press `CH 2`

Channel 2 Control Menu appears

Press `↓` 5 TIMES

Flashing Red Box appears around the Coupling selection

Press `→`

Flashing Red Box appears around ac+dc, ac options

Press `↓`

Select ac only

Press `ENTER`

Flashing Red Box appears around ac selection

Press `HOME`

Flashing Red Box now disappears and ac is selected

Press `HOME`

Display returns to measurement window

PSM3750 user manual

Frequency Sweep Data Settings

FREQUENCY SWEEP CONTROL	
sweep start	100.00 Hz
sweep end	250.00k Hz
steps	100
steps	log
sweep	single
generator when complete	off
graph 1 scaling	auto
graph 2 scaling	auto
frequency marker	off

Action

Result

Press `SWEEP`	Frequency Sweep Control Menu appears
Press `↓`	Flashing Red Box appears around the Sweep Start selection Sweep Start now requires setting
Press `100`	100 now appears in the Sweep Start Option
Press `ENTER`	100Hz has now been selected for the Frequency Sweep start Point
Press `↓`	Flashing Red Box appears around Sweep End selection Sweep End now requires setting
Press `250k`	250k now appears in the Sweep End Option
Press `ENTER`	250 KHz has now been selected for the Frequency Sweep end Point
Press `↓`	Steps Option now selected Steps for plotting Frequency now requires setting
Press `100`	100 now appears in the Steps Option
Press `ENTER`	100 Steps has now been selected for Frequency Plotting
Press `HOME`	Display returns to measurement window

Perform Sweep and Review.

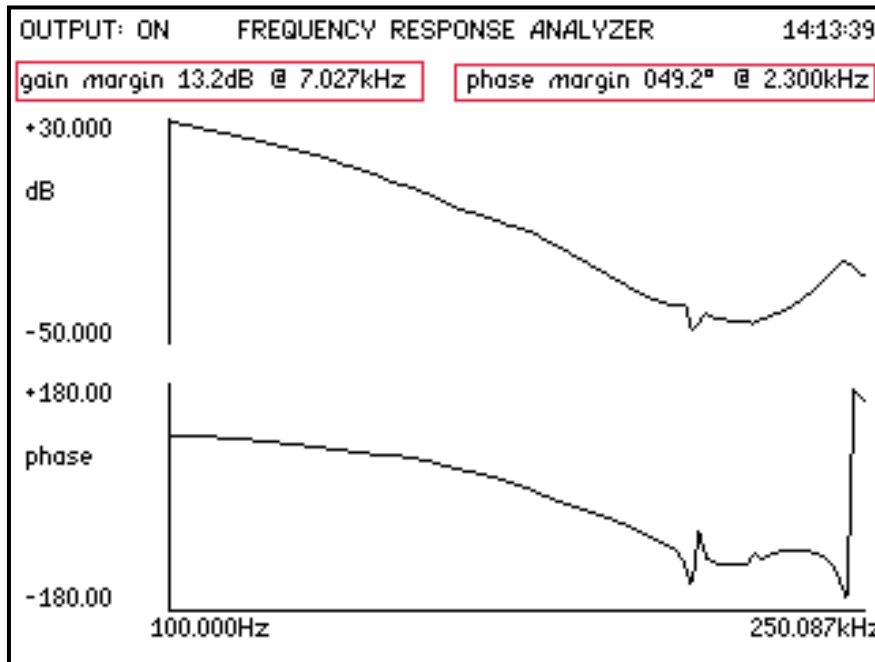

Action

Result

Press 'SWEEP'	Frequency Sweep Control Menu appears
	Check Sweep data parameters (as Frequency Sweep screen)
Press 'SWEEP'	Display returns to measurement screen
Press 'START'	Frequency Sweep will begin
Press 'GRAPH'	View all data from sweep, keep pressing Graph to view more results
Press 'TABLE'	View data from all plotting points
Press 'REAL TIME'	Display returns to measurement window

PSM3750 user manual

Screen Print Options.

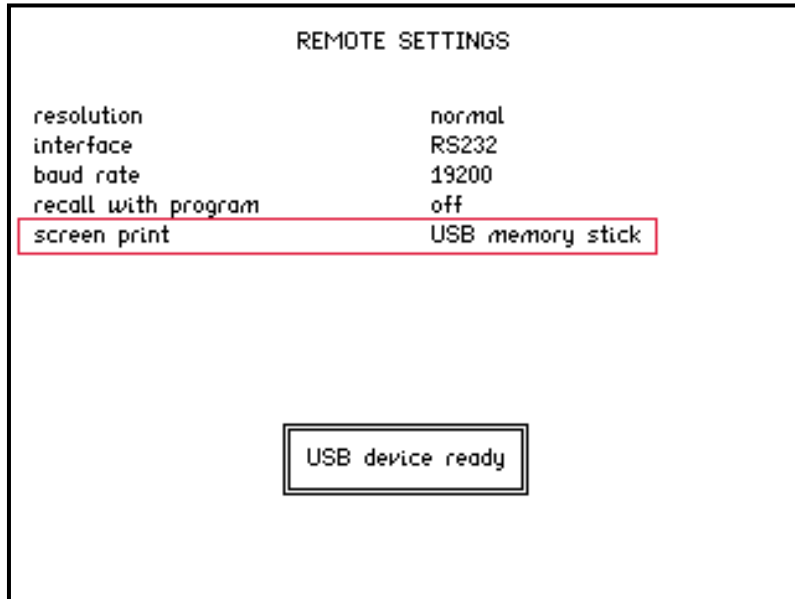

Action

Result

Press 'COMMS'	Remote Settings Control Menu appears
Press '↓' 5 TIMES	Flashing Red Box appears around the Screen Print selection
Press '→'	Flashing Red Box appears around disabled, RS232, USB memory stick
Press '↓'	Select 'USB memory stick' only
Press 'HOME'	USB memory stick mode has now been selected for screen prints
Press 'HOME'	Display returns to measurement window

* The above description applies when the interface used is RS232. It may first be necessary to use the '↓' & '→' keys to select the required interface before following the above steps. The actual number of '↓' key presses required depends on the interface selected.

Frequency response analyser specification

Frequency response (gain/phase) analyser	
frequency	10uHz to 50MHz (own generator) 20mHz to 1MHz (external source)
max input	±500V peak
input ranges	*300mV, *1V, *3V, *10V, *= High Voltage Attenuator. 500V, 300V, 100V, 30V, 10V, 3V, 1V, 300mV, 100mV, 30mV, 10mV, 3mV
ranging	full auto, up only, or manual
input impedance	1M Ohm // 30pF (exc. leads)
magnitude accuracy	0.075% range + 0.075% reading + 50uV <10kHz
(auto)	as above + 0.0003%/kHz < 50MHz
(wide)	as above + 0.003%/kHz < 5MHz
gain accuracy	0.01 dB < 10kHz
(auto)	0.01 dB + 0.0001 dB/kHz < 5MHz
	0.31 dB + 0.00004 dB/kHz < 50MHz
(wide)	0.01 dB + 0.001 dB/kHz < 5MHz
phase accuracy	0.025° < 10kHz
(auto)	0.05° + 0.00025°/kHz < 50MHz
(wide)	0.025° + 0.002°/kHz < 5MHz
CMRR (typical)	160dB @ 230V 50Hz 140dB @ 100V 1kHz 70dB @ 10V 1MHz
sweep step rate	1/20s, 1/3s or 2.5s (approx.)

Conditions:

- 23°C +/- 5°C ambient temperature
- instrument allowed to warm up for ≥30 minutes
- ac+dc coupling
- autoranging or manual ranging ≥ 1/3 range
- signals > 10mV

12 Phase angle voltmeter (vector voltmeter)

A phase angle voltmeter (or vector voltmeter, or phase sensitive voltmeter) measures the signal at one input compared to the phase of the signal at a reference input. The results may be expressed as magnitude and phase, or as separate in-phase and quadrature components.

The PSM3750 measures the in-phase and quadrature components at the fundamental frequency using DFT analysis as described in the section on frequency response analysis. CH2, the measurement input, is phase referred to CH1, the reference input. The individual components are filtered separately to minimise the effects of noise, which would have random phase and would therefore be filtered out. The true rms of the input signals is also computed.

CH1 and CH2 may be voltage inputs or may use external shunts.

From the phase referred fundamental components, ($a + jb$), the following results can be derived:

$$\begin{aligned}
 \text{magnitude} &= \sqrt{a^2 + b^2} \\
 \text{phase} &= \tan^{-1}(b/a) \\
 \tan \phi &= b/a \\
 \text{in-phase ratio} &= a_2 / a_1 \\
 \text{LVDT (diff)} &= \text{scale} * a_2 / a_1 \\
 \text{LVDT (ratio)} &= \text{scale} * (m_1 - m_2) / (m_1 + m_2)
 \end{aligned}$$

Where a_1 and a_2 are the in-phase components, and m_1 and m_2 are the magnitudes, of the signals present at ch1 and ch2 respectively.

The parameter of interest is selected via the PAV or MODE menu. The frequency and phase are always displayed.

PSM3750 user manual

A null meter display may be selected via the PAV menu to allow adjustment of a circuit for minimum phase or component. The parameter on the display depends on the selected component:

parameter	display	null meter
in-phase		in-phase
quadrature		quadrature
$\tan\phi$	$\tan\phi$	$\tan\phi$
magnitude	magnitude	magnitude
phase	phase	
rms	rms	rms2
rms2/1	rms2/rms1	rms2/rms1
in-phase ratio	in-phase ratio	in-phase ratio
LVDT diff	LVDT	LVDT
LVDT ratio	LVDT	LVDT

The null meter may be manually ranged or will automatically range as the signal varies. When manually ranging, ZOOM+ and ZOOM- adjust the range by a decade.

There is a phase offset option that applies a vector rotation of a user selectable phase shift to the CH2 input data.

The PSM3750 can operate either in real time mode at a single frequency where the measurements are filtered and updated on the display; or it can sweep a range of frequencies and present the results as a table or graphs. Before performing a sweep, the desired parameter must be selected.

The frequency points to be measured are specified with three parameters:

- number of steps
- start frequency
- end frequency

PSM3750 user manual

The PSM3750 computes a multiplying factor that it applies to the start frequency for the specified number of steps. Note that due to compound multiplication it is unlikely that the end frequency will be exactly that programmed. The frequency sweep is initiated by the START key, and when completed the data can be viewed as a table or graphs or printed out.

The window over which the measurements are computed is adjusted to give an integral number of cycles of the input waveform. In real time mode the results from each window are passed through a digital filter equivalent to a first order RC low pass filter; in sweep mode each result comprises a single window without any filtering.

The ZOOM function can be used to select up to four parameters from the display when in real time mode. It has no function following a sweep.

Although it is most usual to use the PSM3750 generator when making Phase Angle Voltmeter measurements, there may be circumstances where this is impractical, for example measuring LVDT displacement under actual circuit conditions. In this case, turn off the PSM3750 generator (OUT menu) and the frequency reference for the analysis is measured from channel 1. Provided that the signal is clean enough for an accurate frequency measurement (and for DFT analysis the frequency does need to be accurately known), then the measurements can be made reliably.

When using an external frequency reference there can be no sweep function.

12.1 Phase angle voltmeter specification

Phase angle voltmeter (vector voltmeter)	
frequency	10uHz to 50MHz (own generator) 20mHz to 1MHz (external source)
measurement type measurements	DFT analysis, and true rms Magnitude, Phase, In-Phase & Quadrature components, Tan Φ , In- Phase Ratio, LVDT (diff), LVDT (ratio), Rms, Rms Ratio
phase resolution	0.001°
tan Φ resolution	0.0001
other	as FRA

Conditions:

- 23°C +/- 5°C ambient temperature
- instrument allowed to warm up for ≥ 30 minutes
- ac+dc coupling
- autoranging or manual ranging $\geq 1/3$ range

13 Power meter

The power meter measures the total power and fundamental power of the signal present at the input terminals to the bandwidth of the instrument (>1MHz). Above 5MHz, only the fundamentals are measured.

One of the inputs must be configured as an external shunt input. The external shunt may be a simple resistor or dedicated high frequency precision shunts are available as accessories. Current transformers and clamps may be used if fitted with a suitable burden resistor. For use at mains voltages, a mains power adaptor incorporating voltage and current transformers is available.

The power meter will operate either from its own generator or, more normally, will use the frequency measured on channel 1 (usually voltage).

The power meter measures the elementary values:

- W
- V rms
- A rms
- V fundamental (in-phase and quadrature)
- A fundamental (in-phase and quadrature)
- V dc
- A dc
- V harmonic (in-phase and quadrature)
- A harmonic (in-phase and quadrature)
- frequency

and derives the following values:

- V & A fundamental magnitude
- VA (true and fundamental)
- power factor (true and fundamental)
- fundamental W
- harmonic W
- phase shift

When the integrator function is activated, the following values are available:

- Elapsed time (in hours, minutes and seconds)
- Watt-hours (true and fundamental)
- VA hours (true and fundamental)
- average power factor (true and fundamental)
- Ampere hours (true and fundamental)

The power dissipated in a load subjected to a periodic voltage, $v(\phi)$, with a current flowing $a(\phi)$, is given by:

$$w = 1/2\pi \int_0^{2\pi} v(\phi).a(\phi) d\phi$$

For a sampled signal, the formula becomes:

$$w = 1/n \sum_{i=0}^{i=n-1} v[i].a[i]$$

Where n is the number of samples for an integral number of complete cycles of the input waveform.

These are elementary definitions that are valid for all waveshapes. The PSM3750 computes the true watts value from the elementary definition for sampled data. Formulae for the components at the fundamental frequency are given in the section on frequency response analysis; formulae for the harmonic components are given in the section on harmonic analysis.

The formulae for the derived results are:

$$VA = V_{rms} \times A_{rms}$$

PSM3750 user manual

power factor	= Watts/VA
fundamental Watts	= $V_{\text{real}} \times A_{\text{real}} + V_{\text{quad}} \times A_{\text{quad}}$
harmonic Watts	= $VH_{\text{real}} \times AH_{\text{real}} + VH_{\text{quad}} \times AH_{\text{quad}}$
fundamental VA	= $V_{\text{fund}} \times A_{\text{fund}}$
fund power factor	= $W_{\text{fund}} / VA_{\text{fund}}$

In power meter mode, the UP and DOWN key do not adjust the amplitude but step the harmonic number.

The measurements are computed over rectangular windows with no gaps. The processing power of the DSP allows the measurements to be made in real time without missing any samples. In this way, the measured power is a true value even if the signal is fluctuating. The only occasion when data is missed is when an autozero measurement is requested.

The high linearity of the PSM3750 allows real-time measurements be made on waveforms with periodic bursts such as low standby power PSUs. Use "autorange up" to find the range.

The PSM3750 blanks the results when either of the measured rms signals are low compared to the full scale range. This function can be disabled if desired in the SYSTEM menu.

The ZOOM function can be used to select any combination of up to four parameters from the display.

The integrator is started, or reset, by pressing the START key. The Watt hour integration and the Ampere hour integration can be selected to be signed or magnitude. To integrate the total power in terms of heating effect, choose magnitude. If signed integration is selected then the rms current is given the sign of the power before integration. The Ampere hours and Watt hours then reflect the power

PSM3750 user manual

taken by the load, less any power generated by the load, such as during regenerative braking in battery systems.

13.1 Power meter specification

Power meter	
current input	External shunt or Voltage CT
display	5 digits
measurement	W, VA, PF,V,A, - Total, Fundamental and Integrated, Power Harmonics
coupling	AC+DC, AC(<10VDC), AC(<500VDC)
frequency	DC & 10mHZ to 5MHz 5MHz to 50MHz (fundamentals only) AC 20Hz to 50MHz
max input	±500V peak
input ranges	300mv* 1v* 3v* 10v* *=High Voltage Attenuator: 500V, 300V, 100V, 30V, 10V, 3V, 1V, 300mV, 100mV, 30mV, 10mV, 3mV
ranging	Full Auto, Up Only, or Manual
input impedance	1M Ohm
accuracy (ac)	0.1% range + 0.1% reading +external shunt tolerance
accuracy (dc)	0.2% range + 0.2% reading
CMRR (typical)	160dB @ 230V 50Hz 140dB @ 100V 1kHz 70dB @ 10V 1MHz
time constant	0.2s, 1.5s or 12s

Conditions:

- 23°C +/- 5°C ambient temperature
- instrument allowed to warm up for ≥30 minutes
- sinewave, power factor > 0.7
- slow speed, normal filtering
- ac+dc coupling
- autoranging or manual ranging ≥ 1/3 range
- tolerance of current shunt to be added

14 LCR meter

In LCR meter mode, channel 1 measures the voltage across the component under test, and channel 2 measures the current through it. To measure the current, channel 2 must be connected across an appropriate external shunt.

The easiest way to use the LCR meter is with the 'IAI – impedance analyser interface' (see accessories) that sits under the PSM3750 and provides 4 wire Kelvin clip connections to the component under test. The IAI provides a choice of four shunts, selectable from the front panel, and buffers the signals to minimise the effects of stray capacitance and inductance.

Measurements can be made without the IAI by simply connecting a series shunt. The shunt chosen must be appropriate for the voltage, the current and the frequency of operation.

There are three manual connection options, "shunt", "divider Zx low", "divider Zx high".

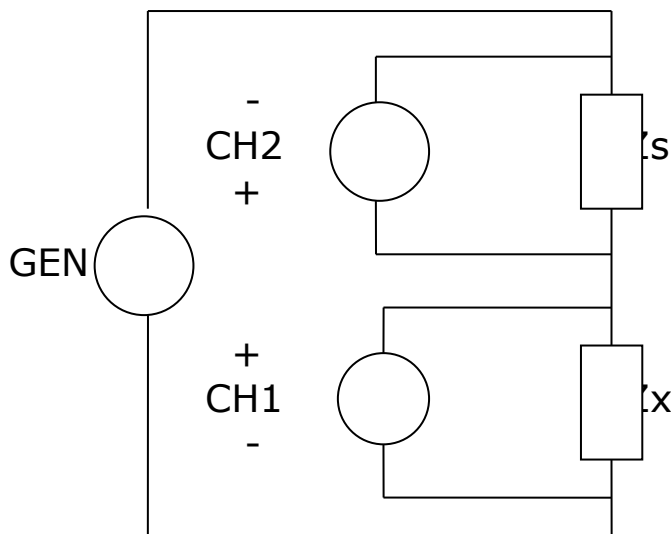

For “shunt” connection, shown above, the current is measured directly across the shunt using CH2 while the voltage across the Z_x is measured by CH1. Notice that the positive inputs to both CH1 and CH2 are connected to the midpoint to minimise common mode loading effects.

Then: $Z_x = Z_s \times \text{CH1} / \text{CH2}$

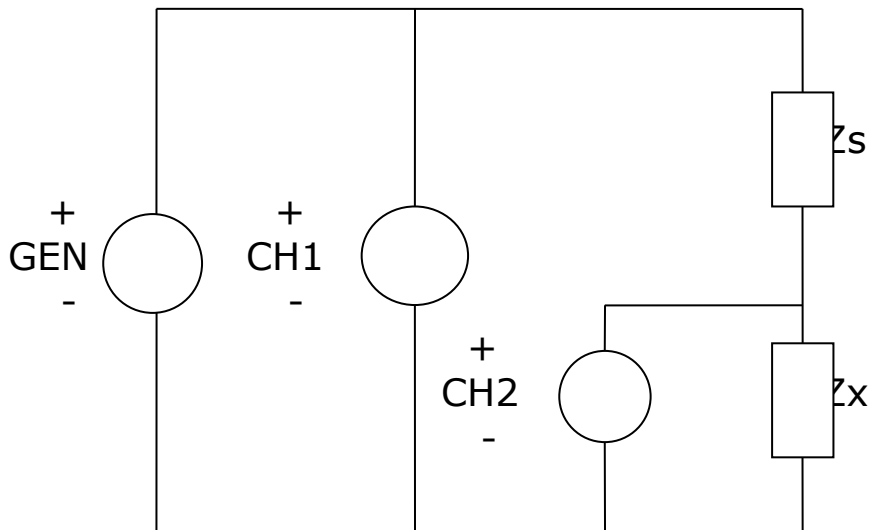

For “divider Z_x low” connection, shown above, the total voltage is measured by CH1 and the voltage arising from the potential divider effect of Z_s and Z_x is measured by CH2. Notice that all the negative terminals are connected together.

Then: $Z_x = Z_s / ((\text{CH1} / \text{CH2}) - 1)$

The connections for “divider Z_x high” are the same as above but with Z_x in the high arm of the potential divider and the shunt in the low arm.

Then: $Z_x = Z_s \times ((\text{CH1} / \text{CH2}) - 1)$

PSM3750 user manual

The PSM3750 measures the real and imaginary components at the fundamental frequency using DFT analysis as described in the section on gain/phase analysis. The frequency may be taken from its own generator or from the circuitry under test.

From the fundamental components of voltage, $(a + jb)$, and those of the current, $(c + jd)$, the PSM3750 computes the complex impedance given by:

$$\begin{aligned} \mathbf{z} &= \mathbf{v} / \mathbf{i} \\ &= (a + jb) / (c + jd) \end{aligned}$$

The components of the complex impedance are filtered independently to minimise the effects of noise, which would have random phase and would therefore be filtered out.

The magnitude of the voltage and current are also computed.

From the complex impedance the following parameters can be derived:

- ac resistance
- inductance,
- capacitance
- impedance
- phase
- $\tan\delta$ (= real/imaginary)
- Q factor (= imaginary/real)

Values are displayed for both series and parallel configurations.

Optionally, the values can be expressed as admittance, conductance, and susceptance instead of impedance, resistance and reactance.

If the parameter option in LCR menu is set to 'auto', the PSM3750 will display capacitance or inductance according to the phase of the measurement. Alternatively, the display can be forced to capacitance, inductance or impedance.

Capacitance is displayed with $\tan\delta$, inductance is displayed with Q factor, and impedance is displayed in its resistive + reactive form and as magnitude. The phase of the impedance is displayed with all options.

The operating conditions for the component under test may be selected manually or the PSM3750 will automatically try to find appropriate conditions.

When measuring large electrolytic capacitors, it may be necessary to add an appropriate bias voltage to polarise the electrodes. In this case it may be necessary to select ac coupling in the CH1 menu in order to reliably measure the small ac voltage present.

When measuring small inductance or capacitance, it may be necessary to zero out the stray effects from the test connections. Press ZERO to access the compensation menu. For inductance connect together the test leads to a good short and select "short circuit" – the message 'SHORT CIRCUIT ZERO SET' will be displayed; for capacitance disconnect the test leads and press ZERO – the message 'OPEN CIRCUIT ZERO SET' will be displayed. To remove the zero, press ZERO then press DELETE within 1.5s – the message 'ZERO CLEARED' will be displayed.

For repeated measurements under the same test conditions (eg. production testing of a batch of capacitors) it is possible to compensate for the inherent phase shift of the connection jig. Connect a known reference component to the system, enter the known phase shift of the component as the "phase reference" in the ZERO menu

and select "phase adjust". The PSM3750 then applies a compensating vector rotation to all subsequent measurements.

The PSM3750 can operate either in real time mode at a single frequency where the measurements are filtered and updated on the display; or it can sweep a range of frequencies and present the results as a table or graphs. Before performing a sweep, either series circuit or parallel circuit must be selected.

The frequency points to be measured are specified with three parameters:

- number of steps
- start frequency
- end frequency

The PSM3750 computes a multiplying factor that it applies to the start frequency for the specified number of steps. Note that due to compound multiplication it is unlikely that the end frequency will be exactly that programmed. The frequency sweep is initiated by the START key, and when completed the data can be viewed as a table or graphs or printed out.

The window over which the measurements are computed is adjusted to give an integral number of cycles of the input waveform. In real time mode the results from each window are passed through a digital filter equivalent to a first order RC low pass filter; in sweep mode each result comprises a single window without any filtering unless repeat sweep is selected.

Very good results can be obtained in a reasonable time using the medium speed setting (e.g. 50 points $\times \sim 1/3s \cong 17s$); for the very best results, use the slow setting (50 points $\times \sim 2.5s \cong 125s$ or 2 minutes, 5 seconds).

The ZOOM function can be used to select up to four parameters from the display when in real time mode. It has no function following a sweep.

Although it is most usual to use the PSM3750 generator when performing LCR measurements, there may be circumstances where this is impractical, for example measuring the inductance of a transformer primary winding under load. In this case, turn off the PSM3750 generator (OUT menu) and the frequency reference for the analysis is measured from channel 1. Provided that the signal is clean enough for an accurate frequency measurement (and for DFT analysis the frequency does need to be accurately known), then the measurements can be made reliably.

When using an external frequency reference there can be no sweep function.

14.1 Nyquist Diagram

The PSM3750 can display impedance on either Bode or Nyquist plots. The Nyquist plot separates the Real and Imaginary components of impedance on an X-Y plot.

To display a Nyquist plot, the PSM must be in LCR meter mode with the measurement parameter set to impedance as shown below:

MEASUREMENT SETTINGS	
mode	lcr meter
parameter	impedance
conditions	auto shunt
graph	linear
measurement	series
connection	shunt
phase offset	+000.00 °
Invert Nyquist	on
Nyquist Origins	on

use AUX menu if using IAI

There two plotting parameters specific to the Nyquist plot:

- Invert Nyquist
 - When enabled, this option inverts the Y (Im) axis on the Nyquist plot.
- Nyquist Origins
 - When enabled, vertical and horizontal dashed lines will indicate the zero point on both the X and the Y-axis (when zero falls within the auto-scale range).

Note: Invert Nyquist is enabled by default.

While in LCR mode, begin a sweep by pressing the START key and then repeatedly press the GRAPH key to toggle through the graphing options until Nyquist is displayed.

PSM3750 user manual

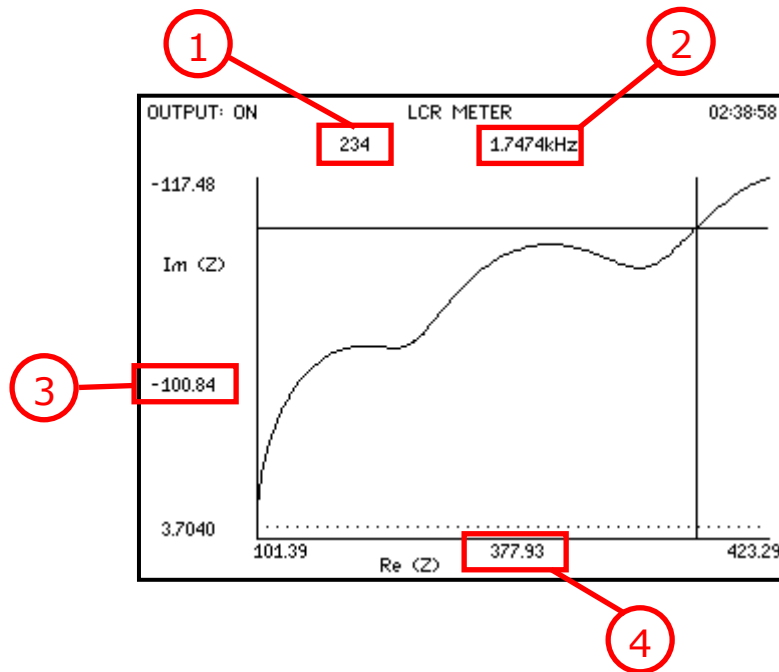

The axes are scaled to fit the sweep and a cursor is automatically displayed. The directional keys on the PSM's front panel can be used to navigate the cursor.

The following parameters are shown for the sweep step and are all updated by movement of the cursor:

1. Sweep step number
2. Frequency
3. Imaginary component of impedance
4. Real component of impedance

14.2 LCR meter specification

LCR meter	
frequency	10uHz to 50MHz (own generator)
measurement type	DFT analysis
measurements	L, C, R (ac), Q, tan δ , impedance, phase, admittance series or parallel circuit
conditions	auto, or manual
display	numeric values table of sweep results graph of any measurement Nyquist (Impedance only)
ranges (with external shunt)	100pF to 100uf 1 μ H to 100H 1 Ω to 1M Ω
ranges (with IAI2)	1pF to 1000uF 10nH to 10kH 1m Ω to 500M Ω
basic accuracy	0.1% + tolerance of Shunt
sweep step rate	1/20s, 1/3s or 2.5s (approx.)

Conditions:

- 23°C +/- 5°C ambient temperature
- instrument allowed to warm up for ≥ 30 minutes
- ac+dc coupling
- autoranging or manual ranging $\geq 1/3$ range
- using impedance interface adaptor

15 Harmonic analyser

The PSM3750 harmonic analyser computes multiple DFTs on the input waveforms in real time (refer to the chapter on frequency response analysis for the formulae for DFT analysis).

There are three modes of operation: single harmonic, difference thd, and series thd. In single harmonic mode, the specified harmonic is displayed both in Volts and as a ratio to the fundamental; in either thd mode, the computed thd and a specified harmonic are displayed as a ratio to the fundamental.

In difference thd mode, the thd is computed from the rms and fundamental:

$$\text{thd} = 1/h_1 \sqrt{(\text{rms}^2 - h_1^2)}$$

In series thd mode, the thd is computed from a series of up to 64 harmonics.

$$\text{thd} = 1/h_1 \sqrt{\sum_{i=2}^{i=n} h_i^2} \quad \text{where } h_i \text{ is the } i^{\text{th}} \text{ harmonic}$$

In series mode the magnitude and phase of all the harmonics can be seen as a table or the magnitudes can be displayed as a bargraph which changes in real time with the measurements. When viewing the bargraph, ZOOM+ and ZOOM- change the vertical axis by a factor of 10.

In all cases the harmonics are phase referred to CH1 fundamental so that their in-phase and quadrature components may be separately filtered to minimise noise.

PSM3750 user manual

The single harmonic and the thd are expressed relative to the fundamental either as a percentage or in dB, as selected via the HARM menu.

The PSM3750 can operate either in real time mode at a single frequency where the measurements are filtered and updated on the display; or it can sweep a range of frequencies and present the results as a table or graphs.

The frequency points to be measured are specified with three parameters:

- number of steps
- start frequency
- end frequency

The PSM3750 computes a multiplying factor that it applies to the start frequency for the specified number of steps. Note that due to compound multiplication it is unlikely that the end frequency will be exactly that programmed. The frequency sweep is initiated by the START key, and when completed the data can be viewed as a table or graphs or printed out.

The window over which the measurements are computed is adjusted to give an integral number of cycles of the input waveform. In real time mode the results from each window are passed through a digital filter equivalent to a first order RC low pass filter; in sweep mode each result comprises a single window without any filtering.

Very good results can be obtained in a reasonable time using the medium speed setting (e.g. 50 points \times $\sim 1/3s \cong 17s$); for the very best results, use the slow setting (50 points \times $\sim 2.5s \cong 125s$ or 2 minutes, 5 seconds).

The ZOOM function can be used to select up to four parameters from the display when in real time mode. It has no function following a sweep.

PSM3750 user manual

Although it is most usual to use the PSM3750 generator when making harmonic measurements, there may be circumstances where this is impractical, for example measuring harmonic currents drawn from the mains. In this case, turn off the PSM3750 generator (OUT menu) and the frequency reference for the analysis is measured from channel 1. Provided that the signal is clean enough for an accurate frequency measurement (and for DFT analysis the frequency does need to be accurately known), then the measurements can be made reliably.

When using an external frequency reference there can be no sweep function.

15.1 Harmonic analyser specification

Harmonic analyser	
fundamental frequency	20mHz to 50MHz (own generator) 20mHz to 1MHz (external source)
harmonic frequency	10uHz to 1MHz
measurement type	multiple DFT analysis
measurements	single harmonic, differential thd, thd by series of harmonics
max harmonic	100
max input	±10V peak
input ranges	10V*, 3V*, 1V*, 300mV* *= High Voltage Attenuator. 500V, 300V, 100V, 30V, 10V, 3V, 1V, 300mv, 100mV, 30mV, 10mV, 3mV.
ranging	full auto, up only, or manual
input impedance	1M // 30pF (exc. leads)
magnitude	0.1% of fundamental + 0.01mV +
accuracy	accuracy of fundamental
sweep step rate	1/20s, 1/3s or 2.5s (approx.)

Conditions:

- 23°C +/- 5°C ambient temperature
- instrument allowed to warm up for ≥30 minutes
- ac+dc coupling
- autoranging or manual ranging ≥ 1/3 range

APPENDICES

Appendix A – Accessories

Power meter adaptors

The power meter adaptors allow easy and safe connection of the PSM3750 to a mains appliance under test to measure the power or harmonics.

The appliance under test plugs into an IEC mains outlet on the adaptor, which contains an isolating voltage transformer and current transformer with precision low resistance shunt.

The adaptor is fitted with an IEC mains inlet for use with an appropriate mains lead.

When the adaptor is plugged into the mains and the mains switched on, the appliance is energised and the PSM3750 can be used to measure the power or harmonics.

Leave the PSM3750 generator off (OUT menu) so that it will synchronise to the mains frequency.

Part numbers

500-058 IEC 10A power meter adaptor

PSM3750 user manual

75Ω / 600Ω output adapter

The generator output from the PSM3750 has a series impedance of 50Ω. The output adapter fits directly onto the front of the instrument and provides 2 outputs:

- 75Ω via a BNC connector
- 600Ω via 4mm sockets.

There are two versions of the adapter that have different spacing between the 4mm sockets:

- 1/2" (12.5mm) as commonly used for communications.
- 3/4" (19mm) as standard on instruments.

In both cases, the red connector carries the output signal, the green or black connector is 0V (connected to earth via the PSM3750 chassis).

The impedance conversion is resistive and does not limit the frequencies available from the generator (dc coupled). When driving into the characteristic impedance (75Ω or 600Ω as appropriate) the voltage delivered to the load will be half that delivered into open circuit.

Matching the source to the load impedance minimises reflections at higher frequencies and improves transient response, especially when driving long lengths of cable or transformers.

Part numbers

500-005	75/600Ω adaptor with 1/2" spacing
500-026	75/600Ω adaptor with 3/4" spacing

PSM3750 user manual

CommView2 PC software

CommView2 is a self contained software program for a PC, which facilitates communication with the PSM3750 over RS232, USB or LAN (if fitted).

CommView2 allows strings to be sent and received between a PC and the PSM3750. The strings can be viewed in a window and optionally stored in a file. Data received from the PSM3750 may be displayed in normal scientific notation with an identifying label.

Strings to be sent to the PSM3750 can be stored in a "script file" and executed automatically. The script file is created with any text editor and includes three types of lines (interpreted by the first character on each line):

- lines beginning with " are sent to the PSM3750
- lines beginning with # are commands for CommView2
- any other line is a comment.

The # commands that are recognised:

#beep	<i>sound the beeper on the PC</i>
#label,i,string	<i>apply a label to data value[i]</i>
#pause,t	<i>wait for time t</i>
#reply,t	<i>wait time t for a reply</i>

For an example script file, look at example.scr on the CommView2 release disc.

Other functions in CommView2:

save results	<i>results menu</i>
set COM port parameters	<i>configure menu</i>
firmware upgrade	<i>instrument menu</i>
read/store user programs	<i>instrument menu</i>

All N4L software applications are available to download free of charge from our website. To find out more please visit us at www.newtons4th.com

PSM3750 user manual

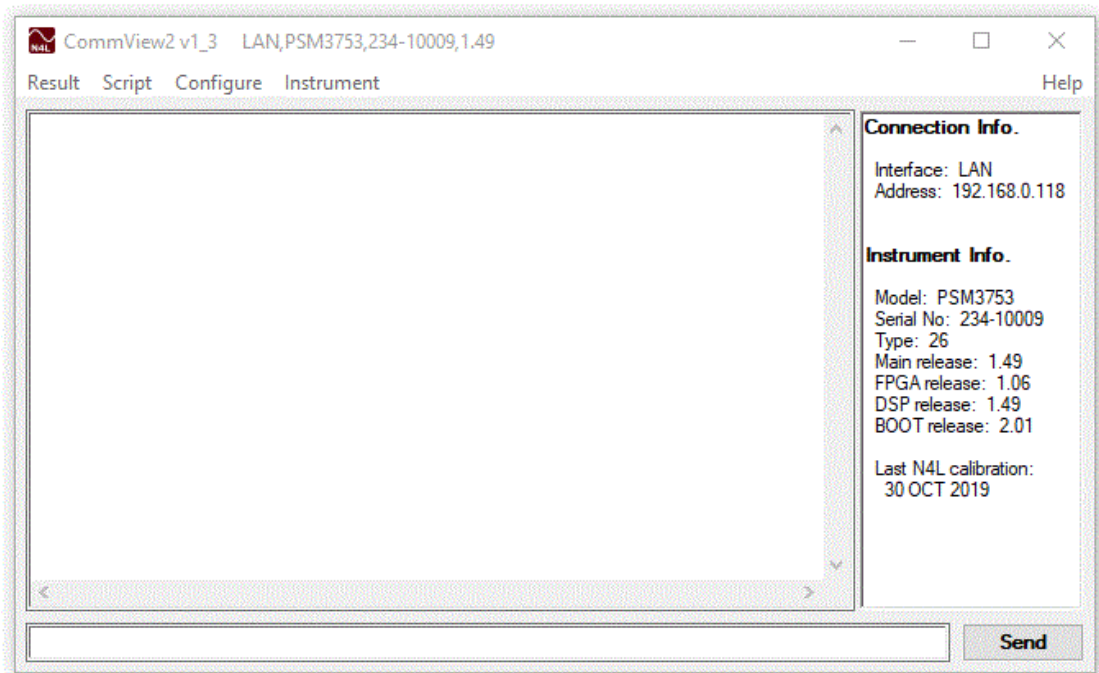

When connecting to the instrument the panel to the right hand side of the software window will display details about the instrument.

This includes:

Connection Information: Details of the interface used to connect the instrument to the PC.

Instrument Information: Instrument Model, Serial number along with firmware details.

Calibration information: Details of when the instrument was last calibrated*

Appendix B – Serial command summary

command format	reply format
*CLS	
*ESE,value	
*ESE?	single integer data value
*ESR?	single integer data value
*IDN?	company,product,serial no,version
*OPC?	0 or 1
*RST	
*SRE,value	single integer data value
*SRE?	
*STB?	single integer data value
*TRG	
*TST?	single integer data value
*WAI	
ABORT	
ACTRIM,channel,level,tol	
ALARM,latch,sounder	
ALARM?	single integer data value
ALARME,value	
ALARME?	single integer data value
ALARM1,type,data,high,low	
ALARM2,type,data,high,low	
AMPLIT,amplitude	
AUXILI,device,value	
BANDWI,type	
BEEP	
BLANKI,on/off,threshold	
CONFIG,parameter,data	
CONFIG,parameter?	single integer or real data value
COUPLI,channel,coupling	
COUPLI,channel?	single integer data value
CYCLES,value	
DATALO,function,interval	
DATALO,start,records?	index,time,data... one record per line
DAV?	single integer data value
DAVER,value	
DAVER?	single integer data value
DELAY,value	
FAST,value	
FILTER,type,dynamics	
FRA	

PSM3750 user manual

FRA?	freq,mag1,mag2,dB,phase
FRA,SWEEP?	n lines of GAINPH? data
FREQUE,frequency	
FSWEEP,steps,start,end	
GAINPH	
GAINPH?	freq,mag1,mag2,dB,phase
GAINPH,SWEEP?	n lines of GAINPH? data
HARMON,scan,para,h,hmax	
HARMON?	freq,mag1,mag2,hmag1,hmag2,h1,h2
or	freq,mag1,mag2,thd1,thd2,h1,h2
HARMON,SWEEP?	n lines of HARMON? data
HARMON,SERIES?	mag1,%1, ϕ 1,mag2,%2, ϕ 2
	1 line for each harmonic
HOLD,on/off	
HVHOME	
INPUT,channel,type	
INPUT,channel?	single integer data value
KEYBOA,value	
LCR,conditions,param,head	
LCR?	freq, mag1, mag2, impedance, phase, R, L, C (series), R, L, C (parallel), tan δ , Q, reactance
or	freq, mag1, mag2, impedance, phase, resistance, reactance, admittance, phase, conductance, susceptance
LCR,SWEEP?	n lines of data: freq,QF,tan δ ,impedance,phase,L,C,R freq,QF,tan δ ,admittance,phase,L,C,R
or	
LOWFRE,on/off	
MARKER,value,frequency	
MODE,type	
MULTIL,index,ch,function	
MULTIL?	Up to 60 data values selected using the MULIL command
NEWLOC	
NOOVER,on/off	
OFFSET,offset	
OUTPUT,type,sweep	
PAV,parameter,scaling	
PAV?	freq,mag1,mag2,parameter,phase,a,b
PAV,SWEEP?	n lines of VECTOR? data
PFCNV,type	
PHASEM	
PHASEM?	freq,phase

PSM3750 user manual

PHASE,STREAM>window	phase,phase,phase,phase,phase,.....
PHCONV,convention	
PHREF,channel	
POWER,integration type	
POWER,WATTS?	W,W.f,VA,VA.f,pf,pf.f,Wdc,W.h,freq
POWER,RMS?	rms1,rms2,dc1,dc2,fnd1,fnd2, ϕ 1, ϕ 2
POWER,INTEGR?	Wh,Wh.f,VAh,VAh.f,pf,pf.f,Ah,Ah.f,t
PROGRAM,function,number	
PROGRAM?	CR terminated text string
RANGE,ch,ranging,range	
RESOLU	
RESULT,function,number	
RESULT?	
REZERO	
SCALE,channel,factor	
SCOPE,channel	data for scope channel
SCOPE?	240 lines of 40 bytes
SCREEN?	
SETUP,index,data	16 lines of ASCII data
SETUP?	
SHUNT,channel,resistance	
SHUNT,channel?	single real data value
SMOOTH,type,dynamics	
SPEED,speed[,window]	
START	
STATUS,channel?	range number,range text,over/low/ok
STOP	
SUSPEND,on/off	
TAGREP,on/off	
TEMPER,type,scalefactor, offset	
TEMPER?	Single data value
TFA	
TFA?	freq,mag1,mag2,dB,phase
TFA,SWEEP?	n lines of GAINPH? data
USER?	3 CR terminated text strings
VARCON,type	
VECTOR,parameter,scaling	
VECTOR?	freq,mag1,mag2,parameter,phase,a,b
VECTOR,SWEEP?	n lines of VECTOR? data
VERSION?	datecode,cpu,dsp,fpga,boot

PSM3750 user manual

VRMS	
VRMS?	RMS? data followed by SURGE?
VRMS,RMS?	rms1,rms2,dc1,dc2,ac1,ac2,db1,db2
VRMS,SURGE?	pk1,pk2,cf1,cf2,surge1,surge2
WAVEFO,type	
WIRING,type	
ZERO	
ZERO,DELETE	
ZOOM,level,d1,d2,d3,d4	
ZOOM?	level,d1,d2,d3,d4

Appendix C – Available character set

The following characters can be selected in text entry mode.

The table is to be read across then down (eg, starting at space and repeatedly pressing NEXT gives ! " # \$ % & ` () * etc.)

	!	"	#	\$	%	&	`
()	*	+	,	-	.	/
0	1	2	3	4	5	6	7
8	9	:	;	<	=	>	?
@	A	B	C	D	E	F	G
H	I	J	K	L	M	N	O
P	Q	R	S	T	U	V	W
X	Y	Z	[\]	^	_
`	a	b	c	d	e	f	g
h	i	j	k	l	m	n	o
p	q	r	s	t	u	v	w
x	y	z	{		}		

Appendix D – Configurable parameters

All parameters can be accessed using the CONFIG command:

```
CONFIG,parameter?
CONFIG,parameter,data
```

Number Function

System parameters

1	operating mode
3	bandwidth auto or wide
4	high voltage protection mode
5	blanking disable
6	phase convention
7	main output on/off
9	keyboard beep on/off
11	low frequency mode
12	user window size
13	measurement speed
14	smoothing filter type
15	smoothing filter dynamics
16	baud rate
18	sweep steps
19	sweep start frequency
20	sweep stop frequency
21	single sweep / continuous sweep
22	auto conditions

Input parameters

24	enable channel 1
25	enable channel 2
26	enable channel 3
27	input ranging channel 1
28	input ranging channel 2
29	input ranging channel 3
30	autoranging CH1
31	autoranging CH2

32	autoranging CH3
33	coupling CH1
34	coupling CH2
35	coupling CH3
36	scale CH1
37	scale CH2
38	scale CH3
39	external Shunt CH1
40	external Shunt CH2
41	external Shunt CH3

Display parameters

42	zoom level
43	function zoomed on 1
44	function zoomed on 2
45	function zoomed on 3
46	function zoomed on 4
47	display type

Signal generator parameters

48	generator frequency
49	generator amplitude
50	generator offset
51	generator waveform
52	delta frequency
53	delta amplitude
54	generator amplitude in dBm

Datalog parameters

58	datalog memory type
59	datalog interval

General parameters

66	program 1-6 direct load
67	DFT Type
69	ignore Overload
72	phase reference
73	DFT selectivity
75	frequency lock

78 high speed mode
84 input

Power meter parameters

86 difference THD
87 PF sign
88 VAr sign

RMS meter parameters

92 rectified mean
93 ratio 2

Harmonic analyser parameters

99 computation
100 selected harmonic
101 maximum harmonic
103 bargraph scale (volts)
104 bargraph scale (current)

LCR single / sweep zero parameters

106 single / sweep compensation
107 sweep compensation start frequency
108 sweep compensation stop frequency
109 sweep compensation steps

System parameters

111 current rating
113 marker
114 marker position
115 high voltage protection message
117 step message enable
118 display sequence
122 auxiliary device / Fixture
131 show scaled external range
132 zoom 2 high resolution

LCR meter parameters

135 invert nyquist

136	nyquist origins
137	parameter
138	series/parallel sweep
139	graph option
140	IAI2 control
141	impedance lin/log
142	reference phase adjust value
143	reference impedance
144	reference type
145	connection
146	phase offset

gain/phase analyser parameters

148	dB offset
149	gain/phase margin enable
150	computation 1

System parameters

151	minimum number of cycles
152	delay time
153	IEEE address
154	interface enable

Alarm functions

156	alarm data
157	type
158	high threshold
159	low threshold
160	latching type
161	sounder enable

Alarm functions

167	alarm 2 data
168	alarm 2 type
169	alarm 2 high threshold
170	alarm 2 low threshold

Graph functions

- 173 graph 2 manual/auto
- 174 graph 2 maximum
- 175 graph 2 minimum

Phase angle voltmeter parameters

- 177 parameter
- 178 LVDT scaling
- 179 manual null meter ranging
- 180 null maximum
- 181 phase offset

Trim parameters

- 186 ac trim enable
- 188 ac trim level
- 190 trim tolerance

Other parameters

- 192 log/linear sweep steps
- 193 graph 1 scaling manual/auto
- 194 manual graph 1 scaling maximum
- 195 manual graph 1 scaling minimum
- 198 Resolution
- 199 LAN IP address 3
- 200 LAN IP address 2
- 201 LAN IP address 1
- 202 LAN IP address 0
- 203 tag comms reply with unit identifier

Scope parameters

- 208 timebase
- 209 trigger level
- 210 pretrigger
- 211 trigger polarity
- 212 trigger mode
- 215 cursors
- 216 trigger HF reject

Generator parameters

219	generator ceiling
221	pulse width
222	amplitude step if dBm control
223	linear frequency step

Appendix E – Environmental Specification

Storage temperature range.	0°C to +50°C
Storage temperature range.	-10°C to +60°C
Relative Humidity Range.	20 to 95% Non-Condensing
Maximum Altitude.	2,000 Metres

Appendix F – Contact details

Please direct all queries or comments regarding the PSM3750 instrument or manual to:

Newton4th Ltd.
1 Bede Island Road
Leicester
LE2 7EA
United Kingdom

Tel: (0116) 230 1066 international +44 116 230 1066
Fax: (0116) 230 1061 international +44 116 230 1061

E-mail address: sales@newtons4th.com
 office@newtons4th.com

Web site: www.newtons4th.com

At Newton4th Ltd. we have a policy of continuous product improvement and are always keen to hear comments, whether favourable or unfavourable, from users of our products.

An example comment form can be found at the end of this manual – if you have any comments or observations on the product please fill a copy of this form with as much detail as possible then fax or post it to us.

Alternatively send an e-mail with your comments.

PSM3750 comments

serial
number:

main release:
dsp release:
fpga release:
boot release:
(press SYS then LEFT)

date:

your contact details:

comments:

detailed description of application or circumstances:

Please post or fax to Newtons4th Ltd.